

 Aguas limpias Uso civil Uso agrícola Uso industrial

CAMPO DE PRESTACIONES

- Caudal hasta **900 l/min** (54 m³/h)
- Altura hasta **107 m**

USOS E INSTALACIONES

Se recomienda para bombear agua limpia y líquidos químicamente no agresivos para los materiales de la bomba.

Debido a su fiabilidad y facilidad de uso, se utilizan ampliamente en los sectores civil, agrícola e industrial, para el suministro de agua, sistemas de aire acondicionado o refrigeración, riego, etc.

LÍMITES DE UTILIZO

- Altura de aspiración manométrica hasta **7 m**
- Temperatura del líquido de **-10 °C** hasta **+90 °C**
- Temperatura ambiente de **-10 °C** hasta **+40 °C**
- Presión máxima en el cuerpo de la bomba **10 bar**

EJECUCIONES A PEDIDO

- ✘ Sello mecánico especial
- ✘ Eje bomba en acero inoxidable AISI 316 - EN 10088-3 - 1.4401 para CP 220, CP 230, CP 250
- ✘ Protección IP X5 para CP 160 y CP 210
- ✘ Diferente voltaje o frecuencia

PATENTES - MARCAS - MODELOS

- Modelo comunitario registrado nº 002098434 para CP 160, CP 210, CP 250
- Modelo italiano registrado nº 72753 para CP 220, CP 230

CP 160

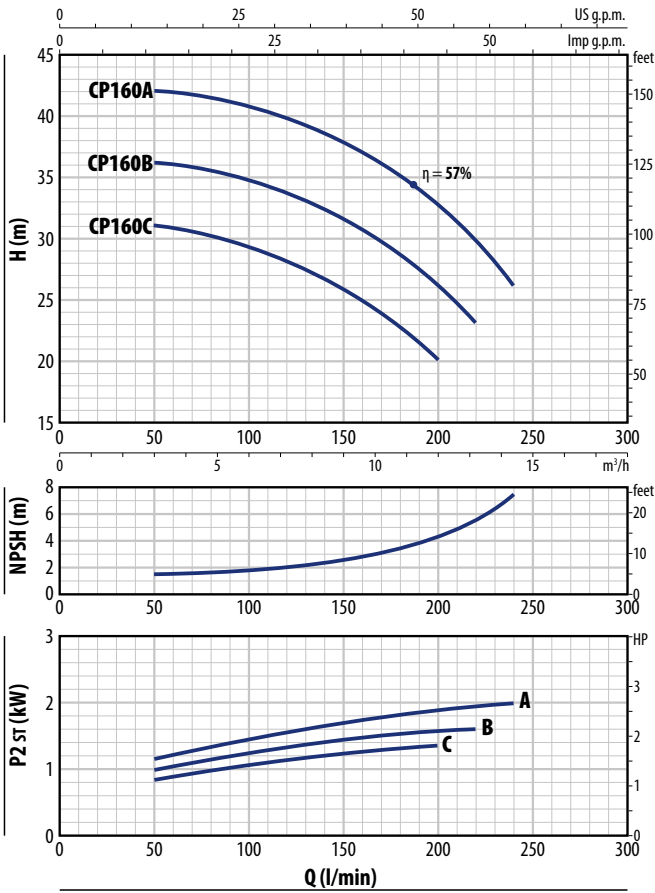

CP 210

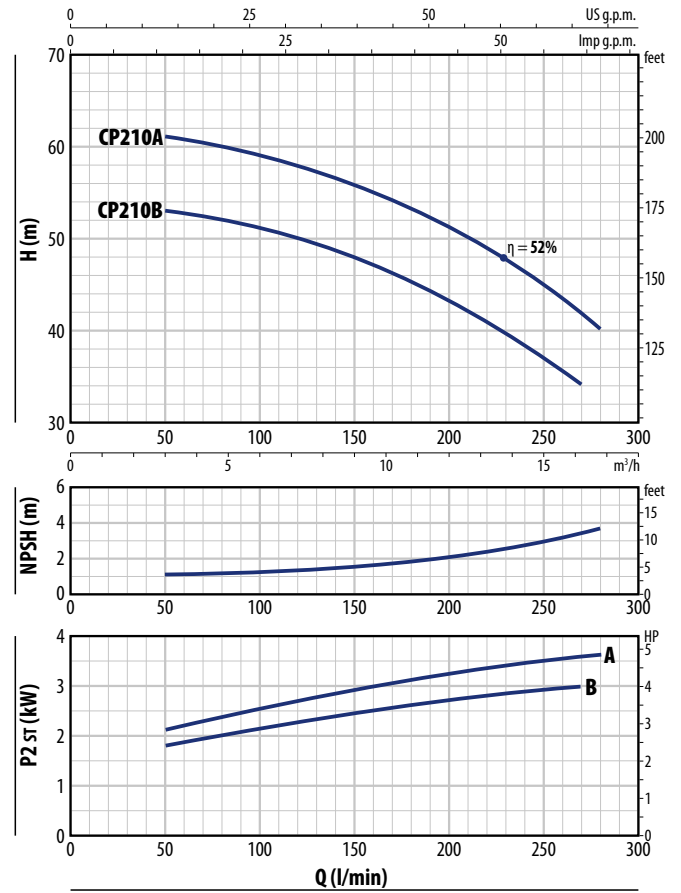

CP 160

TIPO		POTENCIA (P2)		3~	Q	m ³ /h												
Monofásico	Trifásico	kW	HP			0	3	4.5	6	7.5	9	10.5	12	13.2	14.4			
					l/min	0	50	75	100	125	150	175	200	220	240			
CPm 160C	CP 160C	1.1	1.5	IE3	H m	32	31	30.5	29.5	28	26	23	20					
CPm 160B	CP 160B	1.5	2			37	36	35.5	34.5	33.5	31.5	29	26.5	23				
CPm 160A	CP 160A	2.2	3			43	42	41.5	40.5	39.5	38	35.5	33	30	26			

CP 210

TIPO		POTENCIA (P2)		3~	Q	m ³ /h												
Trifásico		kW	HP			0	3	4.5	6	7.5	9	10.5	12	13.2	14.4	15	16.2	16.8
					l/min	0	50	75	100	125	150	175	200	220	240	250	270	280
CP 210B		3	4	IE3	H m	54	53	52	51	49.5	48	45.5	43	40	38.5	37	34	
CP 210A		4	5.5			61	61	60	59	57.5	56	53.5	51	49	46.5	45	42	40

Q = Caudal H = Altura manométrica total HS = Altura de aspiración

Tolerancia de las curvas de prestaciones según EN ISO 9906 Grado 3B.

CP 680

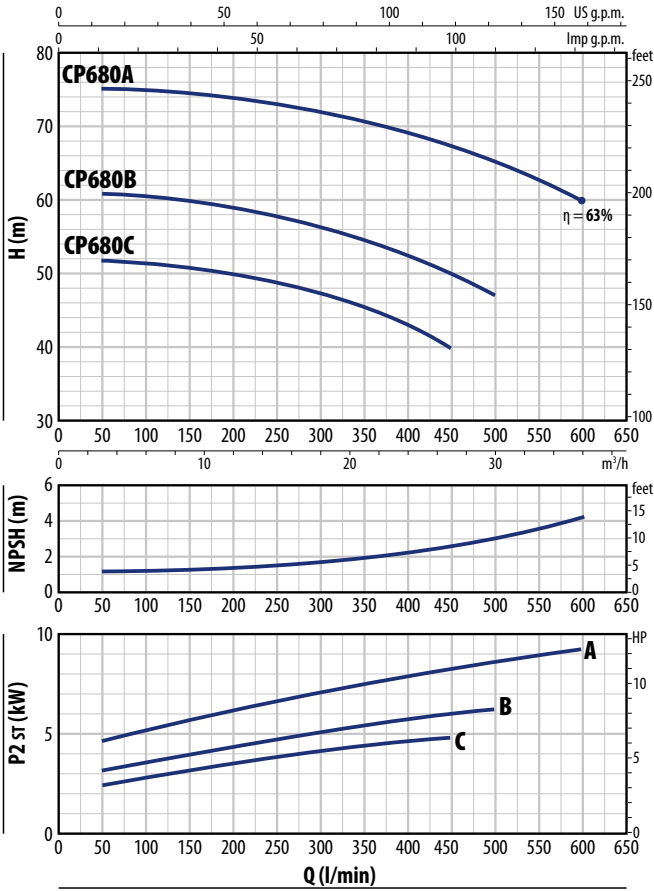

CP 700

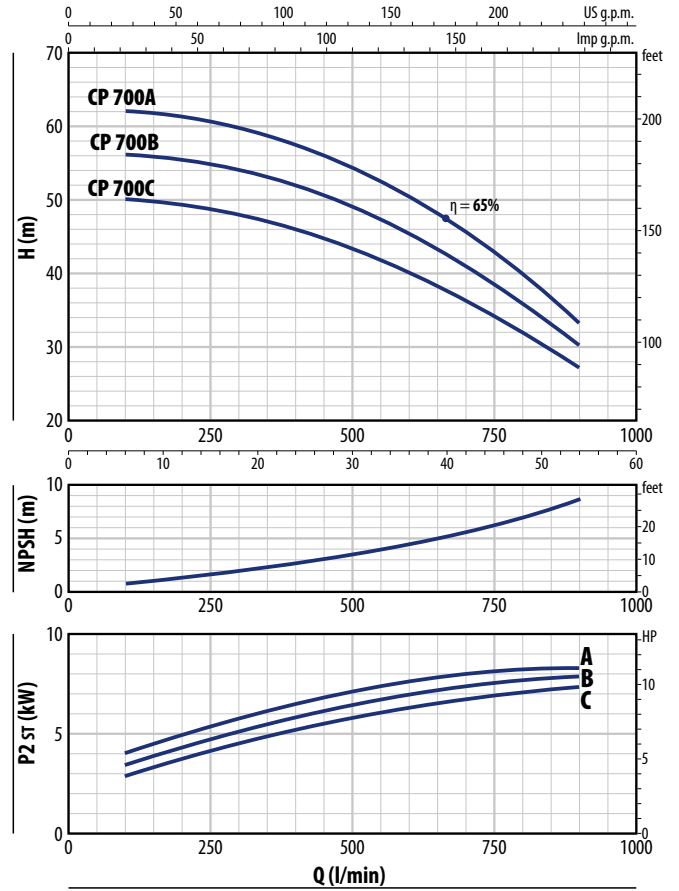

CP 680

TIPO	POTENCIA (P ₂)		3~	Q	m ³ /h														
	Monofásico	Trifásico			kW	HP	0	3	6	9	12	15	18	21	24	27	30	33	36
CPm 680C	CP 680C	4	5.5	IE3	H m	52	51.5	51	50.5	50	49	47.5	45.5	43	40				
-	CP 680B	5.5	7.5			61	60.5	60	59.5	59	58	56.5	54.5	52.5	50	47			
-	CP 680A	7.5	10			75	75	75	74.5	74	73	72	71	68.5	67.5	65	63	60	

CP 700

TIPO	POTENCIA (P ₂)		3~	Q	m ³ /h									
	Trifásico	kW			HP	0	6	12	18	24	30	36	42	48
CP 700C	5.5	7.5	IE3	H m	51	50	49.5	48	46	43.5	40	36.5	32	27
CP 700B	7.5	10			56	56	55.5	54	52	49	45.5	41	36	30
CP 700A	9	12.5			62	62	61.5	60	57.5	54.5	50.5	45.5	39.5	33

Q = Caudal H = Altura manométrica total HS = Altura de aspiración

Tolerancia de las curvas de prestaciones según EN ISO 9906 Grado 3B.

CURVAS Y DATOS DE PRESTACIONES – HS=0 m

60 Hz

CP 750

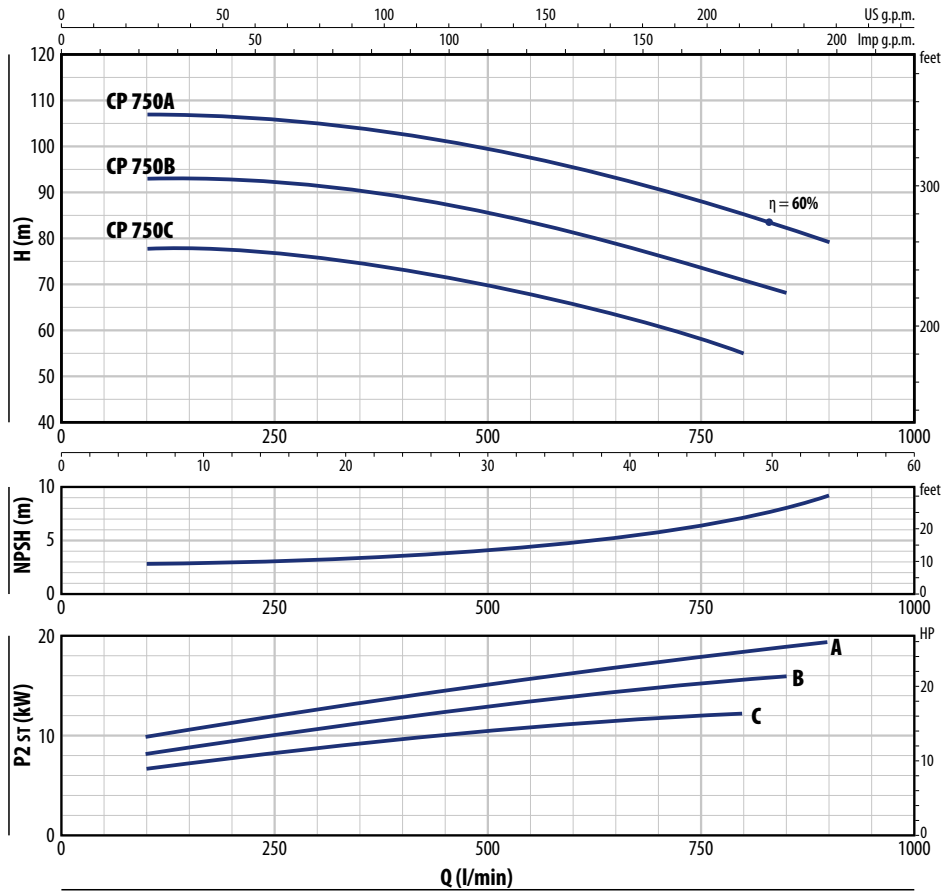

CP 750

TIPO	POTENCIA (P ₂)		3~	Q	m ³ /h														
	kW	HP			0	6	12	18	24	30	36	42	48	51	54				
Trifásico				l/min	0	100	200	300	400	500	600	700	800	850	900				
CP 750C	11	15	IE3	H m	78	78	77	75	72.5	69	65	60.5	55						
CP 750B	15	20			93	93	92	90.5	88	85	81	76.5	71	68					
CP 750A	18.5	25			107	107	106	105	102	99	95	90.5	85	82	79				

Q = Caudal H = Altura manométrica total HS = Altura de aspiración

Tolerancia de las curvas de prestaciones según EN ISO 9906 Grado 3B.

CONSUMOS

TIPO	TENSIÓN
Monofásico	220 V
CPm 160C	9.0 A
CPm 160B	11.0 A
CPm 160A	13.5 A
CPm 680C	28.0 A

TIPO	TENSIÓN			
	220 V - Δ	380 V - Δ	220 V - Δ	440 V - Δ
Trifásico				
CP 160C	6.7 A	3.9 A	7.2 A	3.6 A
CP 160B	7.4 A	4.3 A	6.4 A	3.7 A
CP 160A	8.8 A	5.1 A	8.3 A	4.6 A
CP 210B	14.3 A	8.3 A	11.5 A	6.7 A
CP 210A	18.2 A	10.5 A	16.0 A	10.3 A
CP 680C	20.5 A	12.0 A	18.3 A	10.6 A
CP 680B	25.1 A	14.5 A	21.8 A	12.6 A
CP 680A	34.6 A	20.0 A	32.0 A	18.5 A
CP 700C	27.7 A	16.0 A	23.5 A	13.6 A
CP 700B	33.8 A	19.5 A	28.2 A	16.7 A
CP 700A	34.7 A	20.0 A	29.8 A	17.5 A
CP 750C	41.2 A	23.8 A	44.0 A	23.0 A
CP 750B	58.0 A	34.0 A	52.0 A	27.0 A
CP 750A	62.6 A	36.2 A	65.0 A	34.0 A

DIMENSIONES Y PESOS

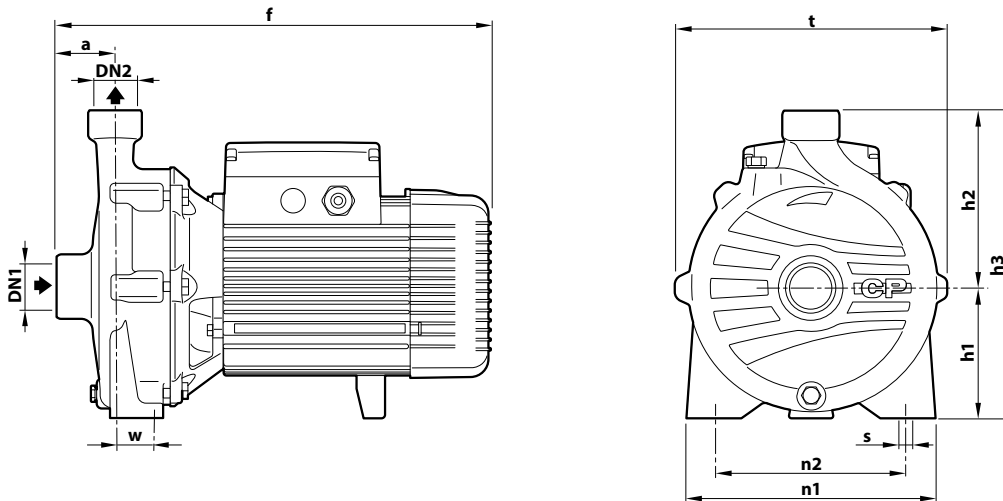

TIPO		BOCAS		DIMENSIONES mm										kg				
Monofásico	Trifásico	DN1	DN2	a	f	h1	h2	h3	t	n1	n2	w	s	1~	3~			
CPm 160C	CP 160C	1½"	1"	54	370	110	150	260	-	206	165	44.5	11	18.7	18.8			
CPm 160B	CP 160B				20.0									20.0				
CPm 160A	CP 160A				22.7									22.9				
-	CP 210B			60	454	132	180	312		274	205	35		-	33.8			
-	CP 210A			-	37.2													
CPm 680C	CP 680C	2" NPT	2" NPT	70	505/460	136	192	328	273	250	190	40	14	47.0	42.0			
-	CP 680B				-									47.0				
-	CP 680A				-									53.0				
-	CP 700C				-									47.0				
-	CP 700B				-									53.0				
-	CP 700A			-	53.5													
-	CP 750C			65	570	160	232	392		317	294	230		45	14	-	93.5	
-	CP 750B			666	-	-	-	-		-	-	-		-	-	-	-	112.0
-	CP 750A			-	120.0													

PALETIZACIÓN

TIPO		GROUPAGE	CONTAINER
Monofásico	Trifásico	nº bombas	nº bombas
CPm 160C	CP 160C	50	70
CPm 160B	CP 160B	50	70
CPm 160A	CP 160A	35	49
-	CP 210B	18	30
-	CP 210A	18	30

TIPO		GROUPAGE	CONTAINER
Monofásico	Trifásico	nº bombas	nº bombas
CPm 680C	CP 680C	18	24
-	CP 680B	18	24
-	CP 680A	12	16
-	CP 700C	12	16
-	CP 700B	12	16
-	CP 700A	12	16
-	CP 750C	6	9
-	CP 750B	6	9
-	CP 750A	6	9

CARACTERÍSTICAS CONSTRUCTIVAS

1 Cuerpo bomba	Hierro fundido con bocas roscadas ISO 228/1			
2 Tapa	Hierro fundido			
3 Rodete	Acero inoxidable para CP160 Latón para CP 210, CP 680, CP 700 Hierro fundido para CP 750			
4 Sello mecánico	Electrobomba	Sello	Eje	Materiales
	CP 160	FN-18	Ø 18 mm	Grafito / Cerámica / NBR
	CP 210 , CP 680, CP 700	FN-24	Ø 24 mm	Grafito / Cerámica / NBR
	CP 750	FN-32 NU	Ø 32 mm	Grafito / Cerámica / NBR
5 Eje motor	Acero inoxidable AISI 431			
6 Motor eléctrico	<p>CPm: monofásico 220 V - 60 Hz con protección térmica del motor integrada en el bobinado. CP: trifásico 220/380 V - 60 Hz o 220/440 V - 60 Hz</p> <ul style="list-style-type: none"> – Las electrobombas trifásicas están equipadas con motores de alta eficiencia clase IE3 (IEC 60034-30-1) – Servicio continuo S1 – Aislamiento: clase F – Protección IPX4 para los modelos CP160 y CP210 – Protección IPX5 para los modelos CP680, CP700, y CP750 			

