

-  Clean water
-  Agricultural use
-  Civil use
-  Industrial use



FIELD PERFORMANCE

- Flow rate up to **1350 l/min** (81 m³/h)
- Head up to **38 m**

INSTALLATION AND USE

WR centrifugal pumps are designed to transfer clean water free from abrasive particles and liquids that will not damage the pump's components.

Suitable for civil and industrial applications such as **heating, air conditioning, cooling, and circulation** systems.

ELECTRIC MOTOR

The three-phase pumps are equipped with newly developed electric motors designed to work with inverters, which guarantee stable and quiet operation.

Efficiency class **IE3** for three-phase motors and **IE2** for single-phase motors, with class F insulation and IPX4 protection.

INCLUDES

- ✘ Pump's impeller directly mounted on the motor shaft.
- ✘ Pump body with suction and discharge ports of identical diameter.

APPLICATION LIMITS

- Manometric suction head up to **7 m**
- Liquid temperature between **-10 °C** and **+110 °C**
- Ambient temperature between **-10 °C** and **+40 °C**
- Maximum pressure in the pump body **10 bar** (PN10)

AVAILABLE UPON REQUEST

- ✘ Counterflange KIT including screws, nuts and gaskets
- ✘ Mechanical seal options available
- ✘ Different voltage requirements 60 Hz frequency

WR 40/125

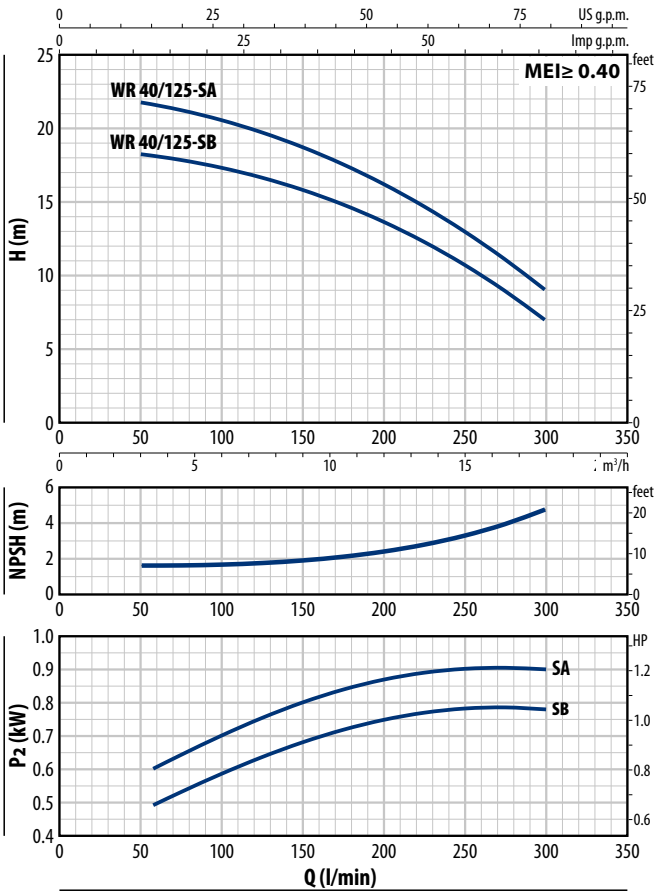

WR 50/125

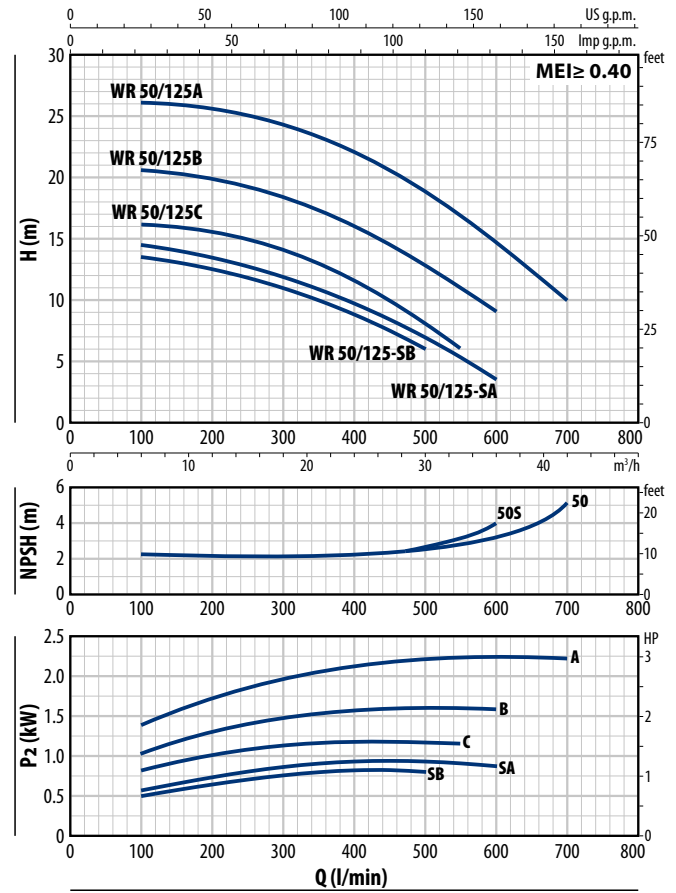

WR 40/125

MODEL		POWER (P ₂)		1~3~	Q	m ³ /h									
Single-phase	Three-phase	kW	HP			0	3	6	9	12	15	18			
WRm 40/125-SB	WR 40/125-SB	0.55	0.75	IE2 IE3	H m	0	50	100	150	200	250	300			
WRm 40/125-SA	WR 40/125-SA	0.75	1			18.7	18.2	17.3	15.8	13.7	10.7	7			
						22.4	21.8	20.6	18.7	16.2	13	9			

WR 50/125

MODEL		POWER (P ₂)		1~3~	Q	m ³ /h												
Single-phase	Three-phase	kW	HP			0	6	12	18	24	30	33	36	39	42			
WRm 50/125-SB	WR 50/125-SB	0.55	0.75	IE2 IE3	H m	0	100	200	300	400	500	550	600	650	700			
WRm 50/125-SA	WR 50/125-SA	0.75	1			14	13.5	12.5	11	8.8	6							
WRm 50/125C	WR 50/125C	1.1	1.5			15	14.5	13.5	11.8	9.7	7	5.5	3.5					
WRm 50/125B	WR 50/125B	1.5	2			16	16	15.5	14	11.5	8	6						
WRm 50/125A	WR 50/125A	2.2	3			20.5	20.5	19.8	18.5	16	12.8	11	9					
						26	26	25.5	24	22	18.5	17	14.5	12.5	10			

Q = Flow rate H = Total manometric head HS = Suction height

Performance curves comply with EN ISO 9906 Grade 3B tolerance limits.

WR 65/125

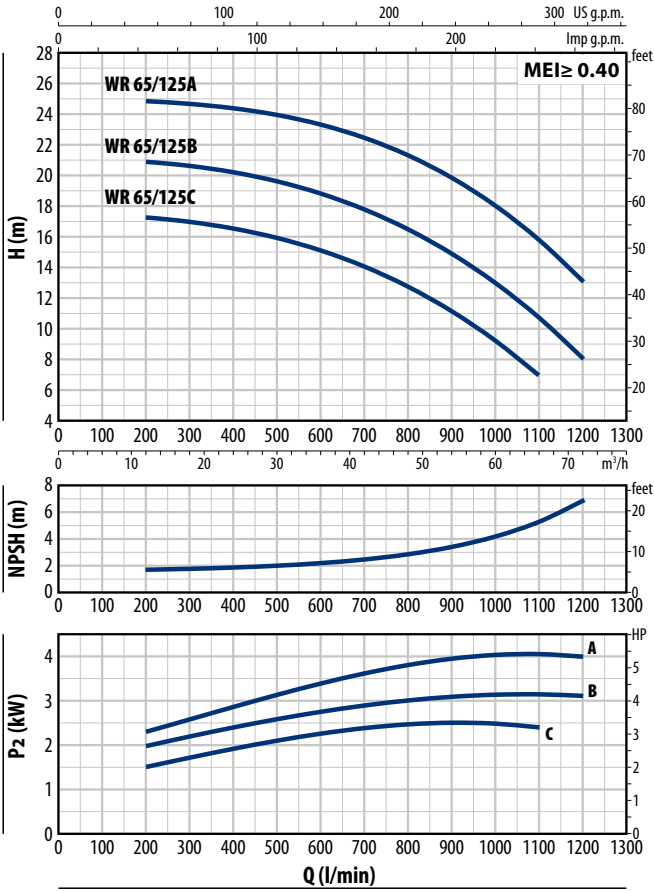

WR 65/160

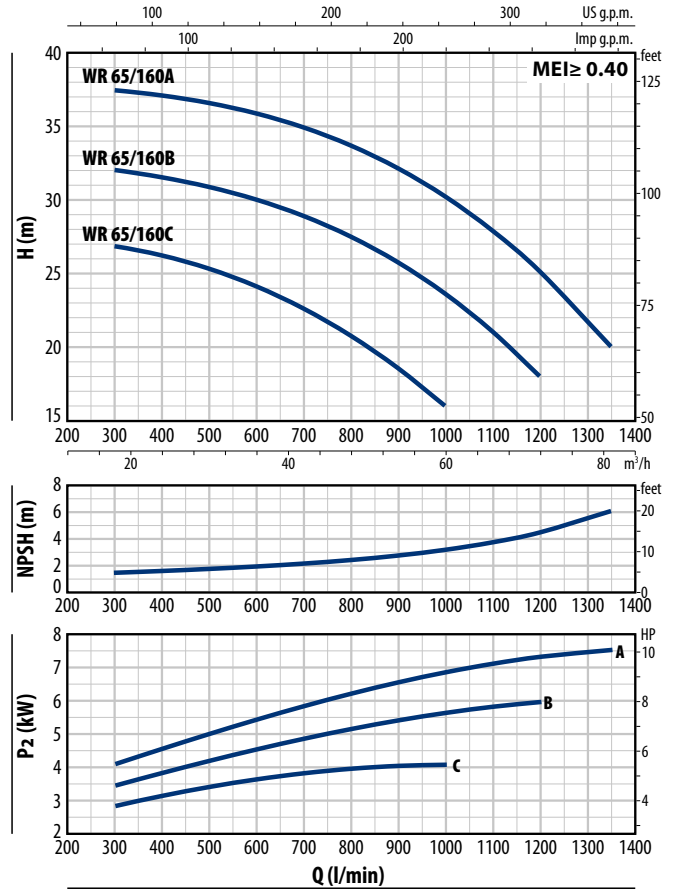

WR 65/125

MODEL	POWER (P ₂)		3~	Q	Flow Rate (Q)												
	kW	HP			0	12	24	36	48	60	66	72	72				
Three-phase					0	200	400	600	800	1000	1100	1200	1200				
WR 65/125C	2.2	3	IE3	H m	17.5	17.3	16.5	15.1	12.8	9.3	7						
WR 65/125B	3	4			21	20.8	20.1	18.8	16.5	13	10.5	8					
WR 65/125A	4	5.5			25	24.8	24.4	23.3	21.3	18	15.7	13	13				

WR 65/160

MODEL	POWER (P ₂)		3~	Q	Flow Rate (Q)														
	kW	HP			0	18	24	30	36	42	48	54	60	66	72	81			
Single-phase					0	300	400	500	600	700	800	900	1000	1100	1200	1350			
WR 65/160C	4	5.5	IE3	H m	27	27	26.5	25	24.5	23	20	18.5	16						
WR 65/160B	5.5	7.5			33	32	31.7	31	30	29	27.4	25.7	23.5	21	18				
WR 65/160A	7.5	10			38	37.5	37	36.5	36	35	33.7	32	30.2	28	25	20			

Q = Flow rate H = Total manometric head HS = Suction height

Performance curves comply with EN ISO 9906 Grade 3B tolerance limits.

ABSORPTION

MODEL	VOLTAGE
Single-phase	230 V
WR 40/125-SB	5.2 A
WR 40/125-SA	6.0 A
WR 50/125-SB	5.2 A
WR 50/125-SA	6.0 A
WR 50/125C	8.0 A
WR 50/125B	10.0 A
WR 50/125A	13.5 A

MODEL	VOLTAGE	
	230 V - Δ	400 V - Y
Three-phase		
WR 40/125-SB	3.6 A	2.1 A
WR 40/125-SA	4.0 A	2.3 A
WR 50/125-SB	3.6 A	2.1 A
WR 50/125-SA	4.0 A	2.3 A
WR 50/125C	5.2 A	3.0 A
WR 50/125B	7.8 A	4.5 A
WR 50/125A	9.0 A	5.2 A
WR 65/125C	11.6 A	6.7 A
WR 65/125B	13.0 A	7.5 A
WR 65/125A	16.0 A	9.2 A
WR 65/160C	15.6 A	9.0 A
WR 65/160B	20.8 A	12.0 A
WR 65/160A	27.7 A	16.0 A

DIMENSIONS

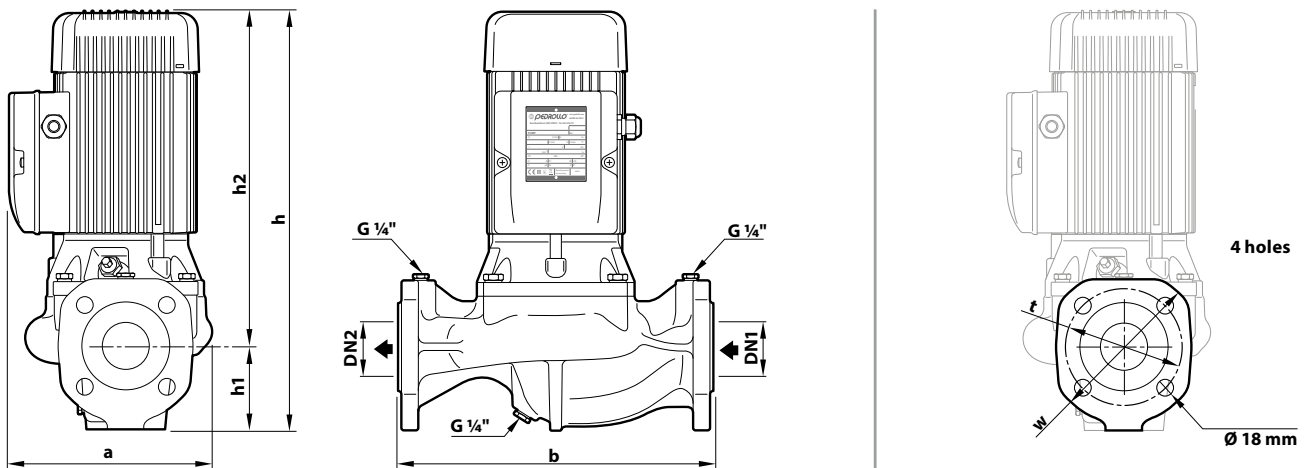

MODEL		PORTS		DIMENSIONS mm							kg
Single-phase	Three-phase	DN1	DN2	a	b	h	h1	h2	w	t	
WRm 40/125-SB	WR 40/125-SB	DN 40	DN 40	195	320	350	81	269	150	110	21.1
WRm 40/125-SA	WR 40/125-SA										
WRm 50/125-SB	WR 50/125-SB	DN 50	DN 50	220	340	432	90	342	165	125	29.0
WRm 50/125-SA	WR 50/125-SA										
WRm 50/125C	WR 50/125C										
WRm 50/125B	WR 50/125B										
WRm 50/125A	WR 50/125A					452		362			32.0
-	WR 65/125C	DN 65	DN 65	260	340	546	105	441	185	145	53.0
-	WR 65/125B										
-	WR 65/125A										
-	WR 65/160C										
-	WR 65/160B										
-	WR 65/160A										
				267		542		437			57.0
				270		592		487			63.0

MATERIALS AND COMPONENTS

1 Pump body Cast iron with cathaphoresis treatment, provided with flanged ports

2 Cover Cast iron with cathaphoresis treatment

3 Impeller Stainless steel **AISI 304**

4 Shaft Stainless steel **AISI 431**

5 Mechanical seal

Elettropompa	Tenuta	Albero	Materiali
WR 40/125-S	FNC-14	Ø 14 mm	Graphite / Silicon carbide / EPDM
WR 50/125-S			
WR 50/125	FN-20E	Ø 20 mm	Graphite / Silicon carbide / EPDM
WR 65/125			
WR 65/160	FN-24E	Ø 24 mm	Graphite / Silicon carbide / EPDM

6 Electric motor

WRm: single-phase 230 V - 50 Hz with capacitor and winding integrated thermal motor protection

WR: three-phase 230/400 V - 50 Hz up to 4 kW
three-phase 400/690 V - 50 Hz from 5.5 kW to 7.5 kW

※ Pumps are equipped with high-efficiency motors (IEC 60034-30-1)
class **IE2** for single-phase models
class **IE3** for three-phase models

Continuous running duty **S1**

