

-  Sewage
-  Domestic use
-  Civil use

※ TRITUS-INOX pumps deliver reliable performance in demanding work conditions



### PERFORMANCE RANGE

- Flow rate up to **250 l/min** (15 m<sup>3</sup>/h)
- Head up to **24 m**

### INSTALLATION AND USE

The **TRITUS-INOX** series is equipped with a robust, **hardened stainless steel blade**, expertly designed to cut through solids and fibers found in domestic wastewater and sewage, for pressurized transfer of materials into sewage systems via small-diameter piping

### INCLUDES

- ※ Power cable length **10 m**
- ※ Float switch (exclusive to single-phase models)

### APPLICATION LIMITS

- Depth below water level up to **5 m** (with an appropriately sized power cable)
- Liquid temperature up to **+40 °C**
- Bottom drainage level up to **85 mm**
- **Minimum immersion for continuous service: 300 mm**

### AVAILABLE UPON REQUEST

- ※ Different voltage or frequency
- ※ Three-phase pumps
- ※ For TIGm 1.1 and TIGm 1.3 external control cabinet for increased operational safety due to special capacitor that significantly increases torque. The panel includes the manual reset motor protection switch.

### PATENTS - TRADE MARKS - MODELS

- Patent No. EP2313658
- Patent No. IT0001428923
- TRITUS® Registered Trade mark No. 013017181

## CURVES AND PERFORMANCE DATA

**60 Hz**

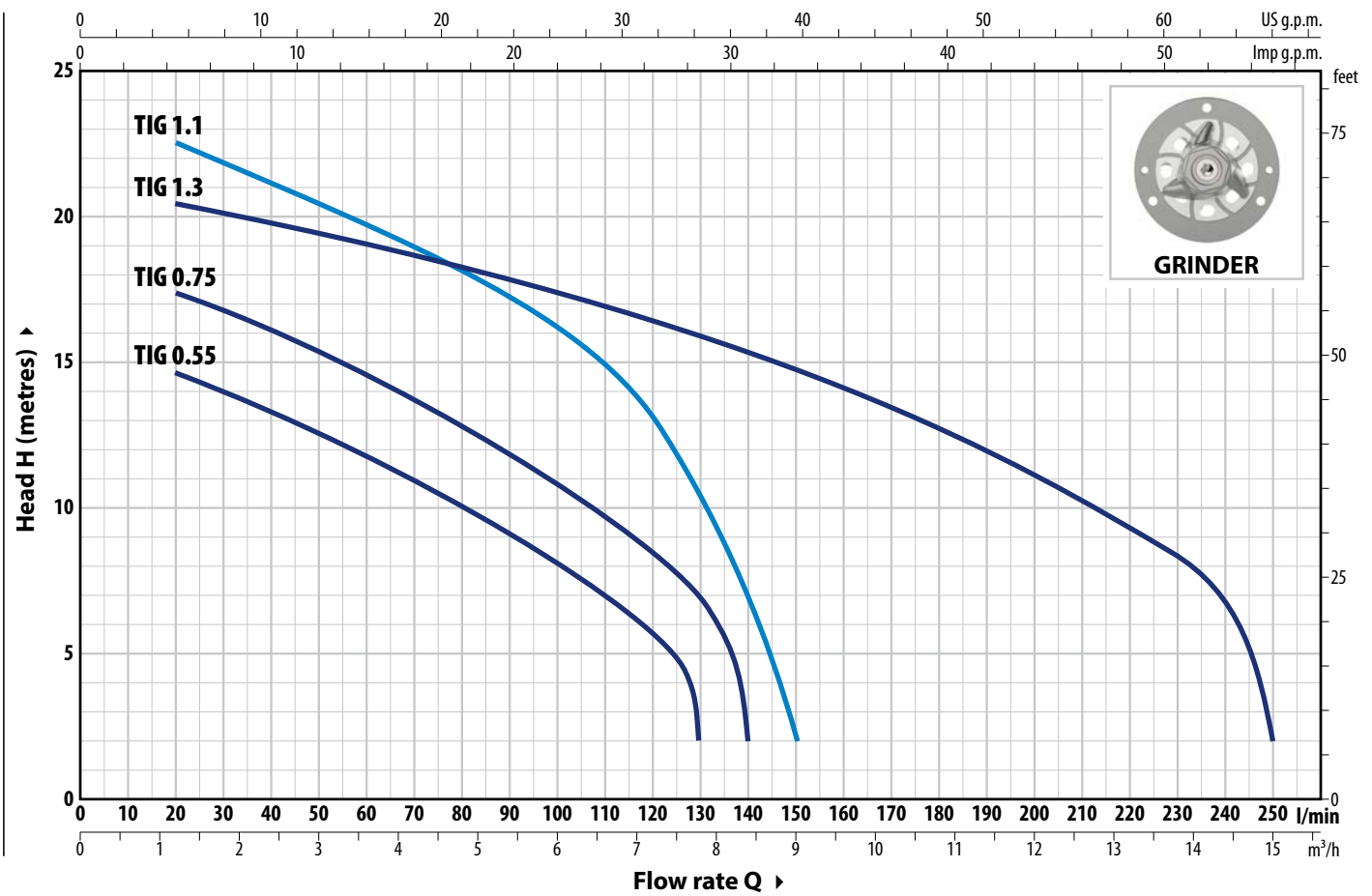

TYPE	POWER (P <sub>2</sub> )		Q	Flow rate (l/min)																
	kW	HP		0	1.2	2.4	3.6	4.8	6	7.2	7.8	8.4	9	10.2	12	13.2	14.4	15		
Single-phase				0	20	40	60	80	100	120	130	140	150	170	200	220	240	250		
<b>TIGm 0.55</b>	0.55	0.75	H metres	16	14.5	13.3	11.8	10	8	5.7	2									
<b>TIGm 0.75</b>	0.75	1		18.5	17.5	16	14.6	12.8	10.8	14	7	2								
<b>TIGm 1.1</b>	1.1	1.5		24	22.5	21	19.5	18	16.3	13	10.4	6.8	2							
<b>TIGm 1.3</b>	1.3	1.75		21	20.5	19.7	19	18.2	17.4	16.5	16	15.4	14.8	13.5	11	9.2	7	2		

Q = Flow rate H = Total manometric head

Performance curves comply with EN ISO 9906 Grade 3B tolerance limits.

## ABSORPTION

TYPE	VOLTAGE	
	220 V	110 V
<b>TIGm 0.55</b>	4.5 A	9.0 A
<b>TIGm 0.75</b>	5.5 A	11.0 A
<b>TIGm 1.1</b>	7.4 A	–
<b>TIGm 1.3</b>	9.0 A	–

# TRITUS-INOX

## DIMENSIONS AND WEIGHT

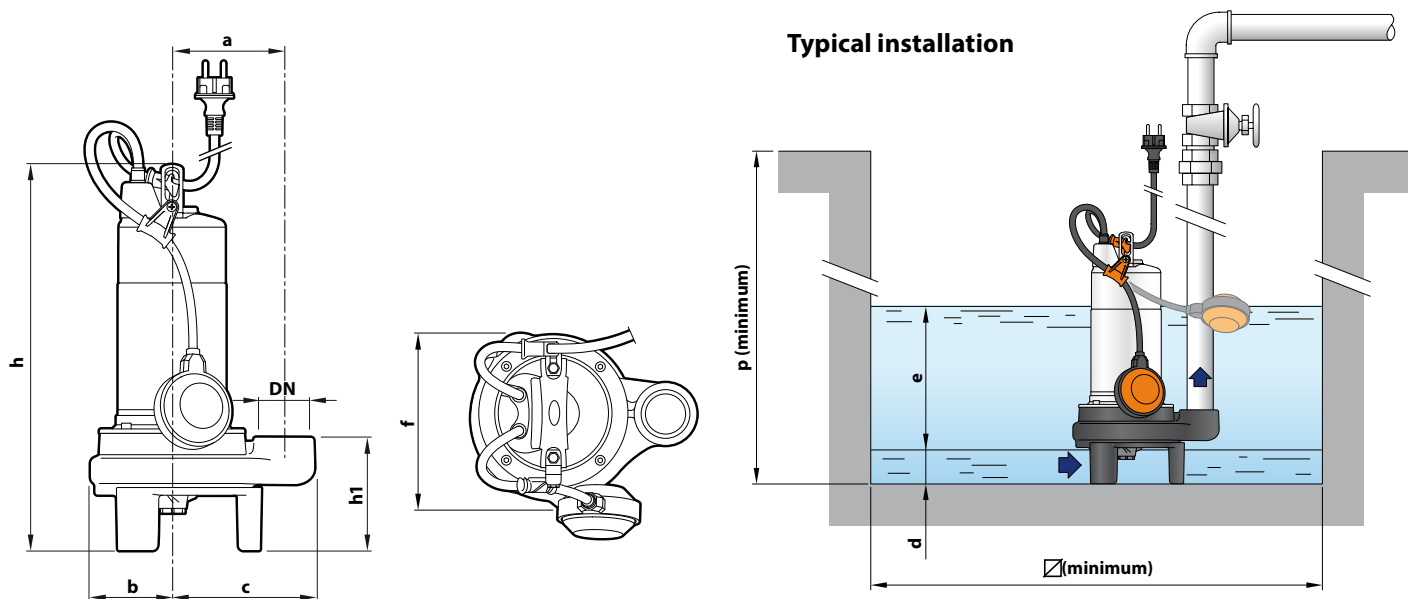

TYPE	PORT DN	DIMENSIONS mm										kg 1~
		a	b	c	f	h	h1	d	e	p	∅	
TIGm 0.55	1½"	115	85	147	177	398	117	65	adjustable	500	500	15.9
TIGm 0.75												16.0
TIGm 1.1			93	195	432	127	70	18.3				
TIGm 1.3								18.3				

## PALLET CAPACITY

TYPE	GROUPAGE	CONTAINER
Single-phase	n. pumps	n. pumps
TIGm 0.55	60	80
TIGm 0.75	60	80
TIGm 1.1	45	60
TIGm 1.3	45	60

## MATERIALS AND COMPONENTS

**1 Pump body** Cast iron with cathaphoresis treatment, provided with ISO 228/1 threaded port

**2 Impeller** Open type in technopolymer

**3 Grinder** Hardened **AISI 440C** stainless steel

**4 Motor shaft** Stainless steel **AISI 431**

**5 Motor sleeve** Stainless steel **AISI 304**

### 6 Double shaft seal with interposed oil chamber

Water pump	Seal	Shaft	Location	Materials
TIG 0.55	<b>MG1-14D SIC</b>	Ø 14 mm	Motor side	SiC / Graphite / NBR
TIG 0.75			Pump side	SiC / SiC / NBR
TIG 1.1	<b>ST1-14 SIC</b>	Ø 14 mm		Ceramic / SiC / NBR
TIG 1.3			<b>Shaft seal</b>	

### 7 Electric motor

Single-phase 220 V - 60 Hz or 110 V - 60 Hz  
with winding integrated thermal motor protection

- Insulation: class F
- Protection rating: IP X8

### 8 Power cord

※ 10 metres 'H07 RN-F' type with Schuko plug

### 9 Float switch

### 10 Tilting device for the float cable

Patent No. IT0001428923

### 11 Power cable strain relief

Patent No. EP2313658

