



※ Electric pumps for industrial use



PERFORMANCE RANGE

- Flow rate up to **50 l/min** (3.0 m³/h)
- Head up to **95 m**

INSTALLATION AND USE

Designed for pumping diesel/naphtha and **clean water** free from abrasive particles and non-corrosive liquids that do not harm the pump's components.

Their hydraulic characteristics, compactness, and small size make them ideal for industrial applications such as chillers, air conditioners, coolers, and boiler feed systems.

PUMP BODY

The **pump body** is made of **CW617N brass**, which guarantees protection against rust and oxidation.

APPLICATION LIMITS

- Manometric suction head up to **8 m**
- Liquid temperature between **-10 °C** and **+90 °C**
- Ambient temperature between **-10 °C** and **+40 °C**
- Maximum working pressure **10 bar**

AVAILABLE UPON REQUEST

- ※ Mechanical seal options available
- ※ Protection rating IP 55 (only for PQ81-Bs and PQ65-Bs)
- ※ Different voltage requirements 60 Hz frequency

PATENTS - TRADE MARKS - MODELS

- Motor bracket: Patent No. IT1243605
- Community Model No. 009068877-0001

CURVES AND PERFORMANCE DATA – HS=0 m

50 Hz

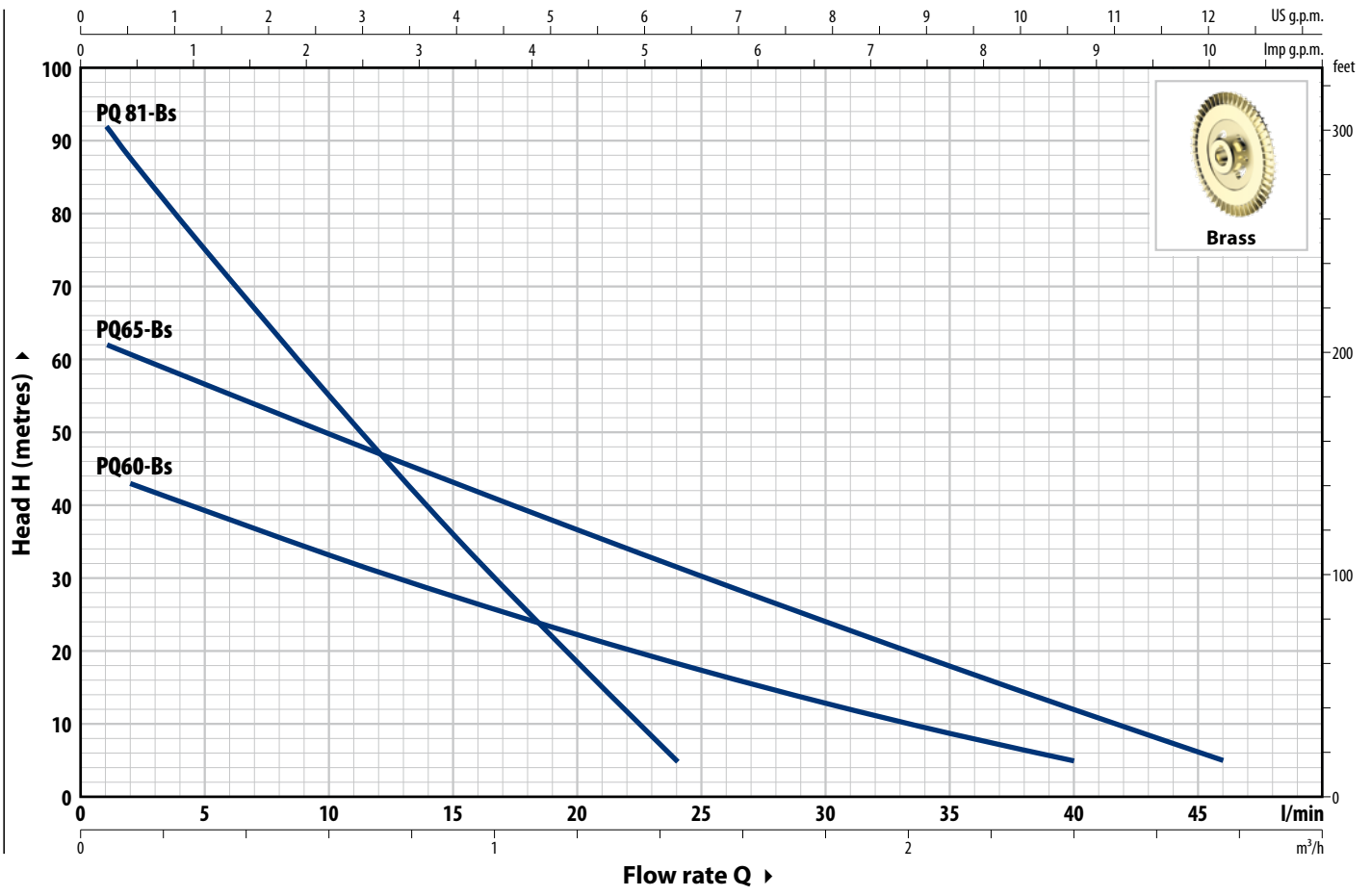

TYPE		POWER (P ₂)		1~3~	Q	m ³ /h															
Single-ph.	Three-ph.	kW	HP			0	0.06	0.12	0.3	0.6	0.9	1.2	1.44	1.8	2.1	2.4	2.76				
						0	1	2	5	10	15	20	24	30	35	40	46				
PQm 60-Bs	PQ 60-Bs	0.30	0.40			45.5	–	43	39	33	27.5	22.3	18.4	12.9	8.8	5					
PQm 65-Bs	PQ 65-Bs	0.55	0.75	IE2	IE3	H metres	63	62	60.5	56.5	49.5	43	36.5	31.5	24	18	12	5			
PQm 81-Bs	PQ 81-Bs	0.55	0.75				96	92	87.5	75	55	36	18.5	5							

Q = Flow rate H = Total manometric head HS = Suction height

Performance curves comply with EN ISO 9906 Grade 3B tolerance limits.

ABSORPTION

TYPE	VOLTAGE
Single-phase	230 V
PQm 60-Bs	2.3 A
PQm 65-Bs	3.7 A
PQm 81-Bs	3.5 A

TYPE	VOLTAGE	
Three-phase	230 V - Δ	400 V - 人
PQ 60-Bs	2.0 A	1.15 A
PQ 65-Bs	2.9 A	1.7 A
PQ 81-Bs	2.4 A	1.4 A

PQ-Bs

DIMENSIONS AND WEIGHT

PQ 60-Bs

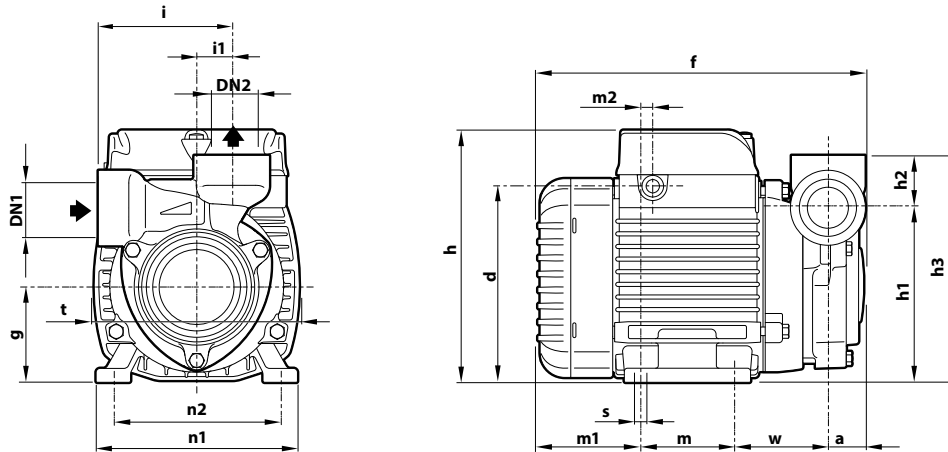

PQ 65-Bs – PQ 81-Bs

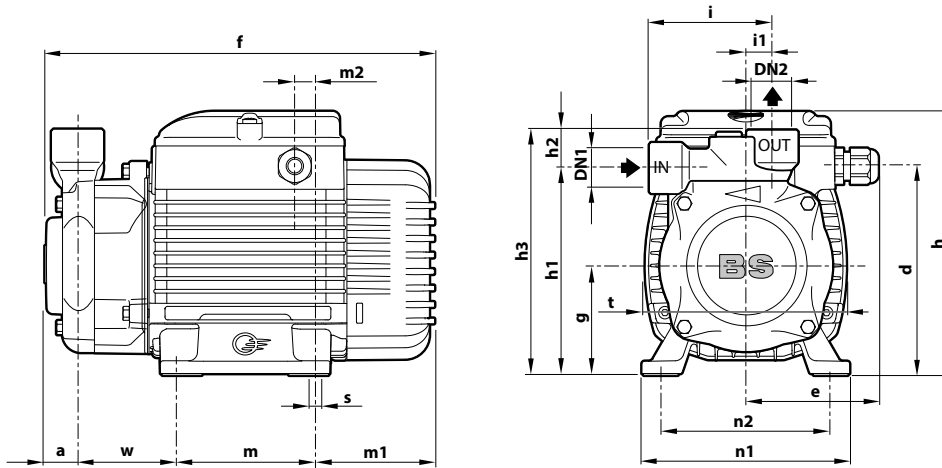

TYPE		PORTS		DIMENSIONS mm																	kg			
Single-ph.	Three-ph.	DN1	DN2	a	d	e	f	g	h	h1	h2	h3	i	i1	m	m1	m2	n1	n2	t	w	s	1~	3~
PQm 60-Bs	PQ 60-Bs	3/4"	3/4"	21.5	112	-	192	56	145.5	101		131			55	62	8	116		118			5.0	5.0
PQm 65-Bs	PQ 65-Bs			24			226				108		30		76	20					100		53.5	
PQm 81-Bs	PQ 81-Bs	1/2"	1/2"	18	119.5	76.5		63	153						80	69	8.5	120		117		7	6.9	6.9

PALLET CAPACITY

TYPE		NO. OF PUMPS
Single-ph.	Three-ph.	
PQm 60-Bs	PQ 60-Bs	238
PQm 65-Bs	PQ 65-Bs	216
PQm 81-Bs	PQ 81-Bs	160

CONSTRUCTION FEATURES

1 Pump body	Brass with ISO 228/1 threaded ports	
2 Motor bracket	Aluminium with brass cover with anti-lock front shim function (patented)	
3 Impeller	Brass, radial peripheral vane type	
4 Mechanical seal	Type	Materials
	ST1-12	Silicon carbide / Graphite / NBR
5 Motor shaft	Stainless steel AISI 431	
6 Electric motor	<p>PQm-Bs: single-phase 230 V - 50 Hz with winding integrated thermal motor protection</p> <p>PQ-Bs: three-phase 230/40 V - 50 Hz</p> <p>※ Pumps are equipped with high-efficiency motors (IEC 60034-30-1)</p> <p>class IE2 for single-phase models</p> <p>class IE3 for three-phase models</p> <ul style="list-style-type: none"> – Continuous running duty S1 – Insulation: class F – Protection rating: IP X4 	

