



PERFORMANCE RANGE

- Flow rate up to **2900 l/min** (174 m³/h)
- Head up to **23.8 m**
- Power from **0.37 to 9.2 kW**

INSTALLATION AND USE

- Designed to transfer clean water free from abrasive particles and liquids that will not damage the pump's components.
- Water supply
- Pressurization
- Irrigation
- Water circulation in air conditioning systems
- Power washing systems
- Firefighting systems
- Industrial applications
- Agriculture applications

Installation is to be carried out in well-ventilated enclosed locations or otherwise protected from the weather.

ELECTRIC MOTOR

The three-phase pumps are equipped with newly developed electric motors designed to work with inverters, which guarantee stable and quiet operation.

Efficiency class **IE3** for three-phase motors, **IE2** for single-phase motors, class F insulation and IP55 protection.

APPLICATION LIMITS

- Manometric suction head up to **7 m**
- Liquid temperature between **-10 °C** and **+90 °C**
- Ambient temperature between **-10 °C** and **+40 °C**
- Maximum pressure in the pump body **10 bar (PN10)**

AVAILABLE UPON REQUEST

- ✘ Different voltage requirements 60 Hz frequency
- ✘ Handling of liquids with higher or lower temperatures
- ✘ Adaptability to operate in high or low temperature environments
- ✘ Counterflange KIT including screws, nuts and gaskets



PERFORMANCE RANGE - n= 1750 min⁻¹

60 Hz

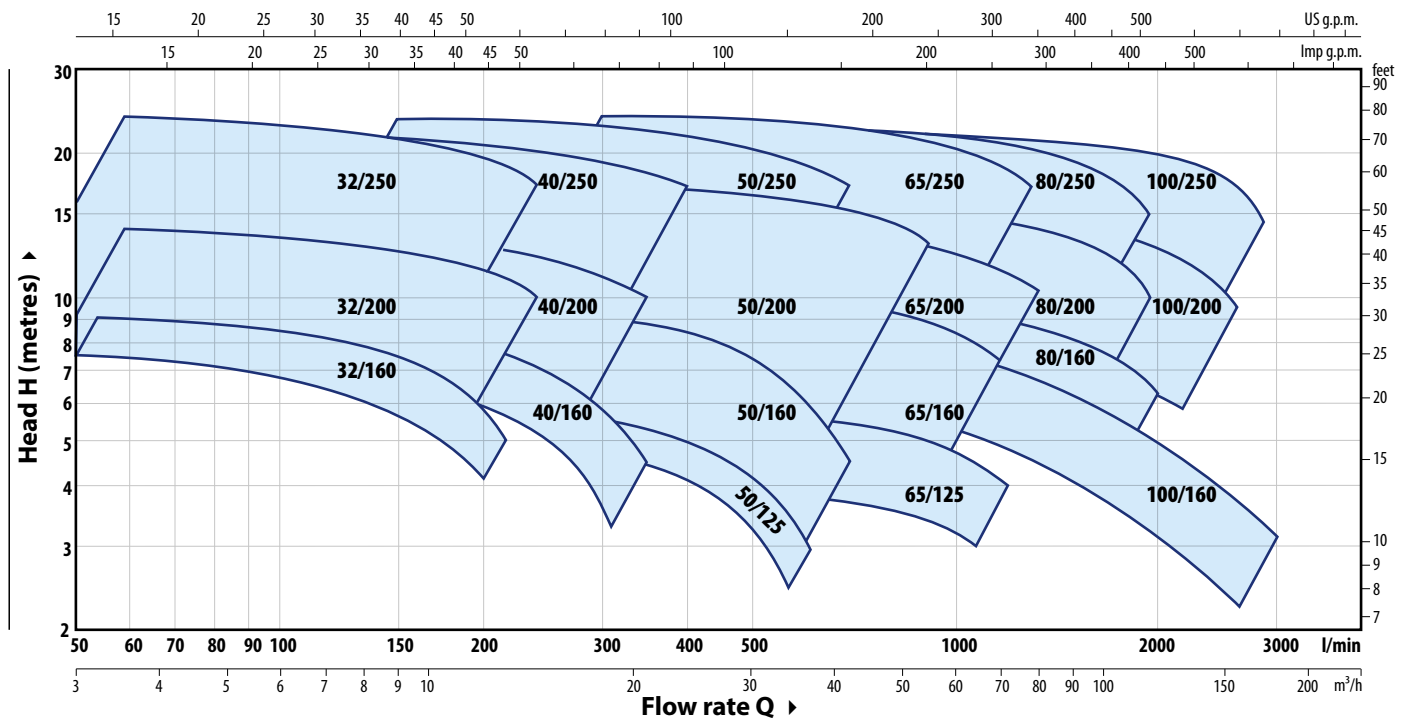

PERFORMANCE DATA - n= 1750 min⁻¹

60 Hz

TYPE	POWER (P ₂)		PERFORMANCE		
	Three-ph.	kW	HP	Q l/min	H m
F4-32/160B	0.37	0.5		50 – 200	7.5 – 4.5
F4-32/160A	0.37	0.5		50 – 225	9 – 5
F4-32/200B	0.75	1		50 – 250	12.5 – 9
F4-32/200A	1.1	1.5		50 – 250	14 – 10.5
F4-32/200BH	0.75	1		50 – 150	11.3 – 9.2
F4-32/200AH	0.75	1		50 – 160	13.8 – 11
F4-32/250C	1.1	1.5		50 – 220	18.4 – 15
F4-32/250B	1.5	2		50 – 250	21.7 – 17.4
F4-32/250A	2.2	3		50 – 270	23.8 – 18.7
F4-40/160B	0.37	0.5		50 – 320	7.5 – 3.5
F4-40/160A	0.55	0.75		50 – 350	9 – 4.5
F4-40/200B	0.75	1		50 – 350	11.5 – 7
F4-40/200A	1.1	1.5		50 – 350	13.8 – 10
F4-40/250C	1.1	1.5		50 – 400	15.5 – 10
F4-40/250B	1.5	2		50 – 400	17.5 – 12
F4-40/250A	2.2	3		50 – 400	22 – 17
F4-50/125B	0.55	0.75		150 – 600	5 – 2
F4-50/125A	0.55	0.75		150 – 600	6 – 3
F4-50/160B	0.75	1		150 – 650	8 – 3.8
F4-50/160A	1.1	1.5		150 – 700	9.3 – 4.5
F4-50/200C	1.5	2		200 – 850	11 – 7.5
F4-50/200B	2.2	3		200 – 850	13 – 9.5
F4-50/200A	2.2	3		200 – 900	15 – 11.2
F4-50/200AR	3	4		200 – 900	17 – 13.2
F4-50/250D	1.1	1.5		150 – 650	12.5 – 5
F4-50/250C	1.5	2		150 – 700	14 – 5
F4-50/250B	2.2	3		150 – 700	18 – 10.5
F4-50/250A	2.2	3		150 – 700	20 – 13
F4-50/250AR	3	4		150 – 700	23.5 – 17

TYPE	POWER (P ₂)		PERFORMANCE		
	Three-ph.	kW	HP	Q l/min	H m
F4-65/125B	0.75	1		300 – 1100	4.7 – 3
F4-65/125A	1.1	1.5		300 – 1200	5.7 – 4
F4-65/160C	1.1	1.5		300 – 1100	8 – 5.5
F4-65/160B	1.5	2		300 – 1200	9.1 – 5.7
F4-65/160A	2.2	3		300 – 1200	10.1 – 7
F4-65/200A	2.2	3		300 – 1250	12 – 8.5
F4-65/200AR	3	4		300 – 1300	14 – 10
F4-65/250B	4	5.5		200 – 1250	21.8 – 15.5
F4-65/250A	5.5	7.5		200 – 1300	23.5 – 17
F4-80/160D	1.5	2		300 – 2000	6.3 – 2.5
F4-80/160C	2.2	3		300 – 2000	7.5 – 3.8
F4-80/160B	2.2	3		300 – 2000	8.8 – 5
F4-80/160A	3	4		300 – 2000	10 – 6.2
F4-80/200B	4	5.5		300 – 1800	14 – 9
F4-80/200A	5.5	7.5		300 – 1900	15.5 – 10.5
F4-80/250B	5.5	7.5		300 – 1800	19.5 – 13.5
F4-80/250A	7.5	10		300 – 1950	22 – 15
F4-100/160A	3	4		400 – 2800	10 – 4.7
F4-100/200C	4	5.5		400 – 2300	12.7 – 7
F4-100/200B	5.5	7.5		400 – 2400	14.2 – 8.5
F4-100/200A	5.5	7.5		400 – 2600	15.8 – 9.5
F4-100/250B	7.5	10		400 – 2600	18.5 – 11.5
F4-100/250A	9.2	12.5		400 – 2900	22 – 13.5

Q = Flow Rate

H = Total manometric head

Performance curves comply with EN ISO 9906 Grade 3B tolerance limits.

F4-32

CURVES AND PERFORMANCE DATA – n= 1750 min⁻¹

HS= 0 m 60 Hz

F4-32/160

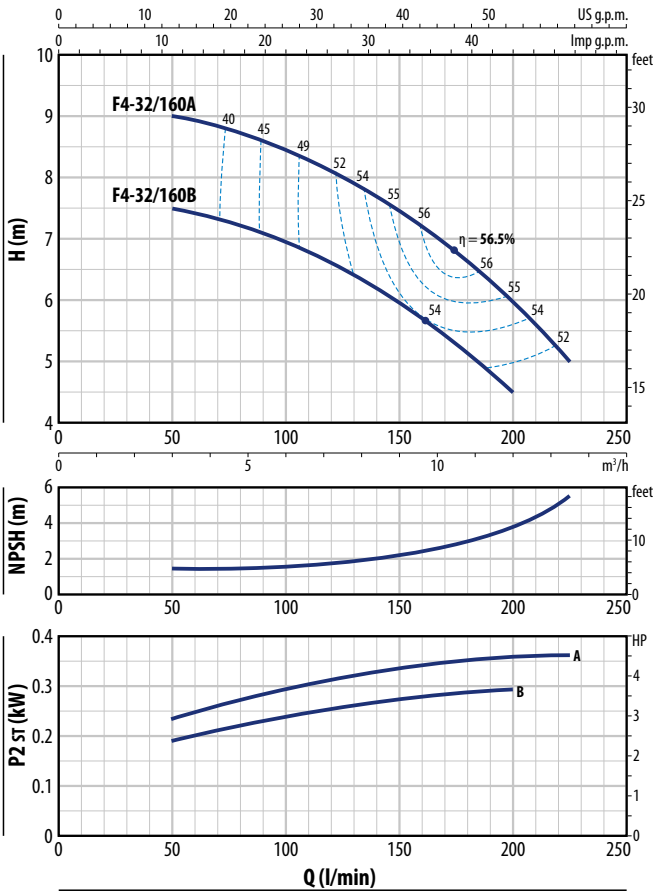

F4-32/200

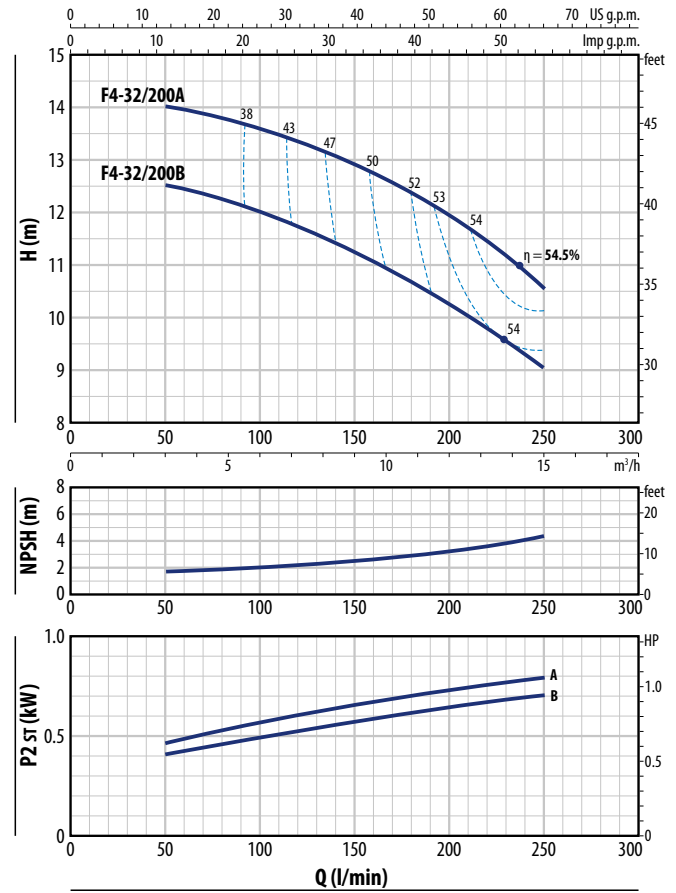

F4-32/160

TYPE	POWER (P ₂)		3~	Q	Flow rate								
	kW	HP			m ³ /h	3	4.5	6	7.5	9	10.8	12	13.5
Three-phase				l/min	50	75	100	125	150	180	200	225	
F4-32/160B	0.37	0.5	IE3	H m	7.5	7.3	6.9	6.5	6	5.1	4.5		
F4-32/160A	0.37	0.5			9	8.8	8.4	8	7.5	6.6	6	5	

F4-32/200

TYPE	POWER (P ₂)		3~	Q	Flow rate					
	kW	HP			m ³ /h	3	6	9	12	15
Three-phase				l/min	50	100	150	200	250	
F4-32/200B	0.75	1	IE3	H m	12.5	12	11.2	10.3	9	
F4-32/200A	1.1	1.5			14	13.6	12.8	11.9	10.5	

Q = Flow rate H = Total manometric head HS = Suction height

Performance curves comply with EN ISO 9906 Grade 3B tolerance limits.

F4-32/200H

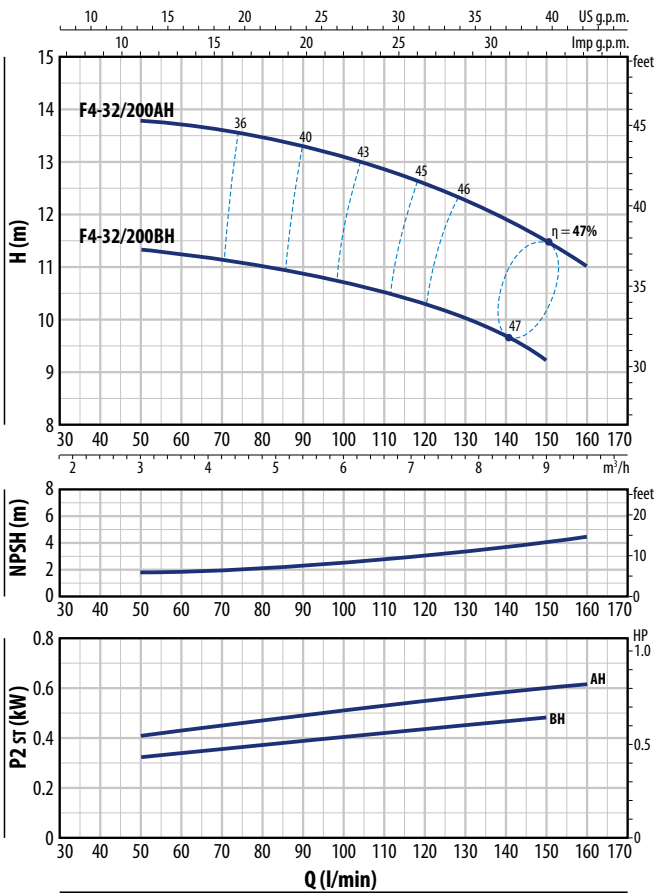

F4-32/250

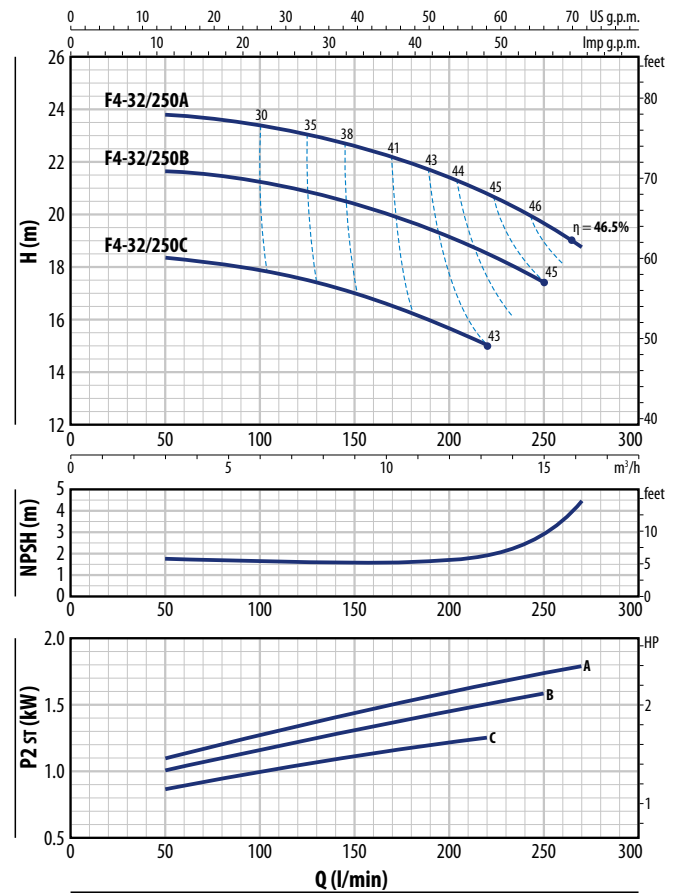

F4-32/200H

TYPE	POWER (P ₂)		3~	Q	Q							
	kW	HP			m ³ /h	3	4.2	5.4	6.6	7.8	9	9.6
Three-phase				l/min	50	70	90	110	130	150	160	
F4-32/200BH	0.75	1	IE3	H m	11.3	11.1	10.8	10.5	10	9.2		
F4-32/200AH	0.75	1			13.8	13.6	13.3	12.8	12.2	11.5	11	

F4-32/250

TYPE	POWER (P ₂)		3~	Q	Q									
	kW	HP			m ³ /h	3	4.5	6	7.5	9	10.5	13.2	15	16.2
Three-phase				l/min	50	75	100	125	150	175	220	250	270	
F4-32/250C	1.1	1.5	IE3	H m	18.4	18.1	17.8	17.5	17	16.4	15			
F4-32/250B	1.5	2			21.7	21.5	21.2	20.9	20.4	19.8	18.5	17.4		
F4-32/250A	2.2	3			23.8	23.6	23.4	23	22.6	22.1	20.8	19.6	18.7	

Q = Flow rate H = Total manometric head HS = Suction height

Performance curves comply with EN ISO 9906 Grade 3B tolerance limits.

F4-40

CURVES AND PERFORMANCE DATA – n= 1750 min⁻¹

HS= 0 m **60 Hz**

F4-40/160

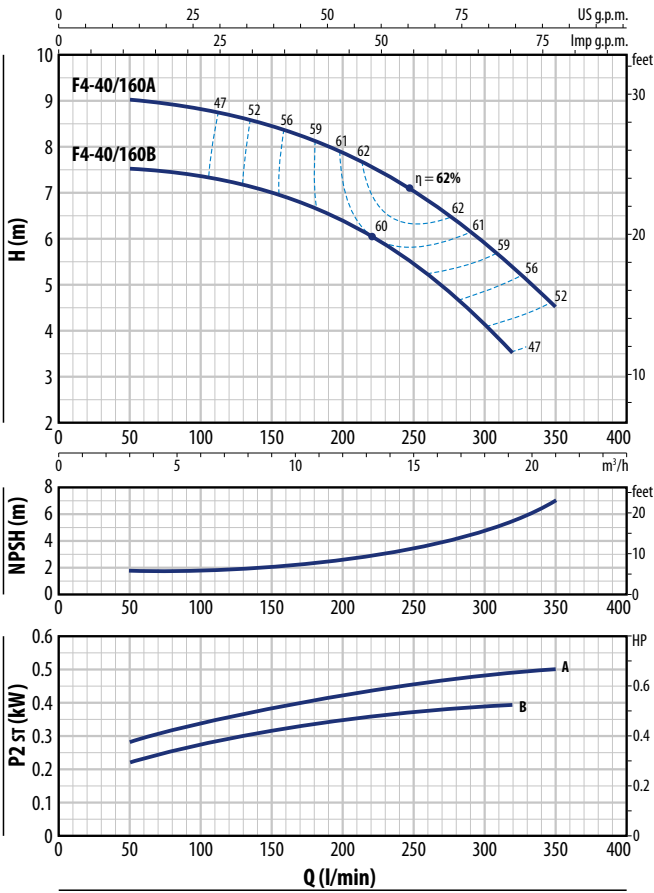

F4-40/200

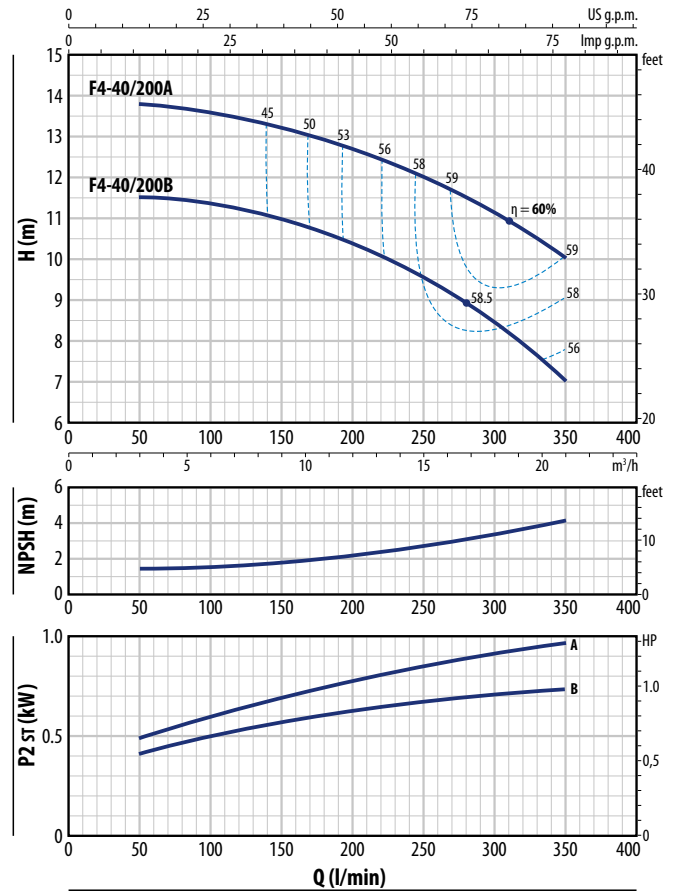

F4-40/160

TYPE	POWER (P ₂)		3~	Q	m ³ /h								
	kW	HP			3	6	9	12	15	18	19.2	21	
Three-phase				l/min	50	100	150	200	250	300	320	350	
F4-40/160B	0.37	0.5	IE3	H m	7.5	7.4	7	6.4	5.4	4.1	3.5		
F4-40/160A	0.55	0.75			9	8.9	8.7	8.1	7.1	5.8	5.3	4.5	

F4-40/200

TYPE	POWER (P ₂)		3~	Q	m ³ /h							
	kW	HP			3	6	9	12	15	18	21	
Three-phase				l/min	50	100	150	200	250	300	350	
F4-40/200B	0.75	1	IE3	H m	11.5	11.4	11	10.4	9.5	8.5	7	
F4-40/200A	1.1	1.5			13.8	13.6	13.2	12.7	12	11.1	10	

Q = Flow rate H = Total manometric head HS = Suction height

Performance curves comply with EN ISO 9906 Grade 3B tolerance limits.

F4-40/250

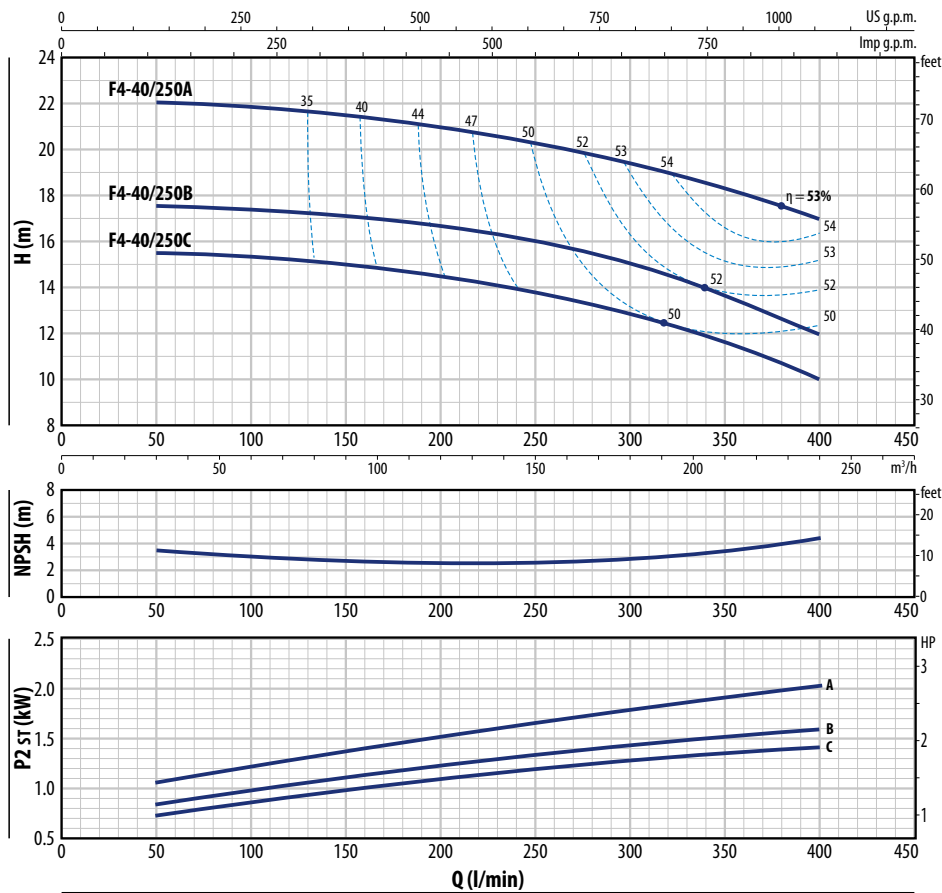

F4-40/250

TYPE	POWER (P ₂)		3~	Q	m ³ /h								
	kW	HP			3	6	9	12	15	18	21	24	
Three-phase				l/min	50	100	150	200	250	300	350	400	
F4-40/250C	1.1	1.5	IE3	H m	15.5	15.2	15	14.5	13.6	12.9	11.5	10	
F4-40/250B	1.5	2			17.5	17.2	17	16.5	16	15	13.5	12	
F4-40/250A	2.2	3			22	21.9	21.5	21	20.2	19.2	18.2	17	

Q = Flow rate H = Total manometric head HS = Suction height

Performance curves comply with EN ISO 9906 Grade 3B tolerance limits.

F4-50

CURVES AND PERFORMANCE DATA - n= 1750 min⁻¹

HS= 0 m 60 Hz

F4-50/125

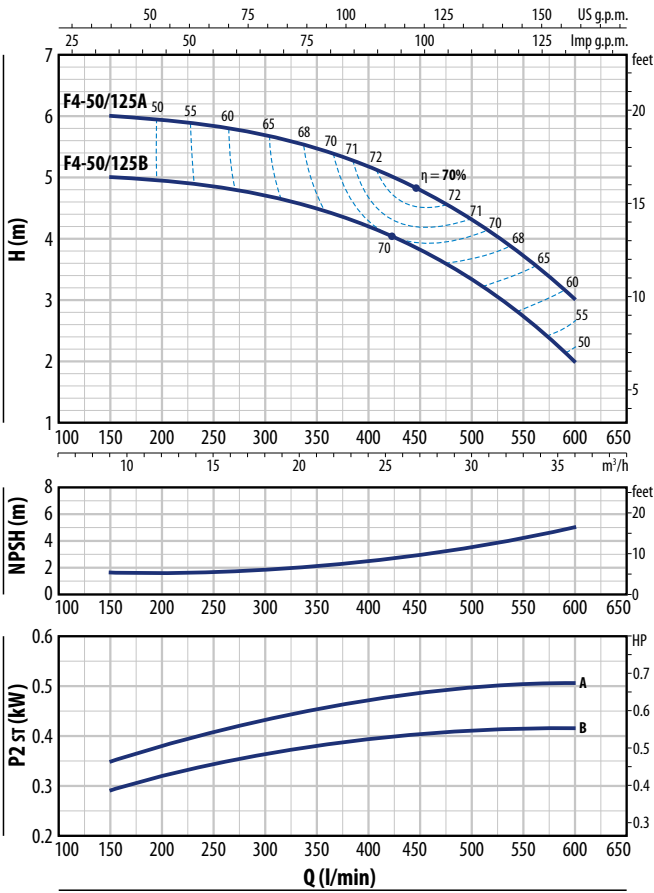

F4-50/160

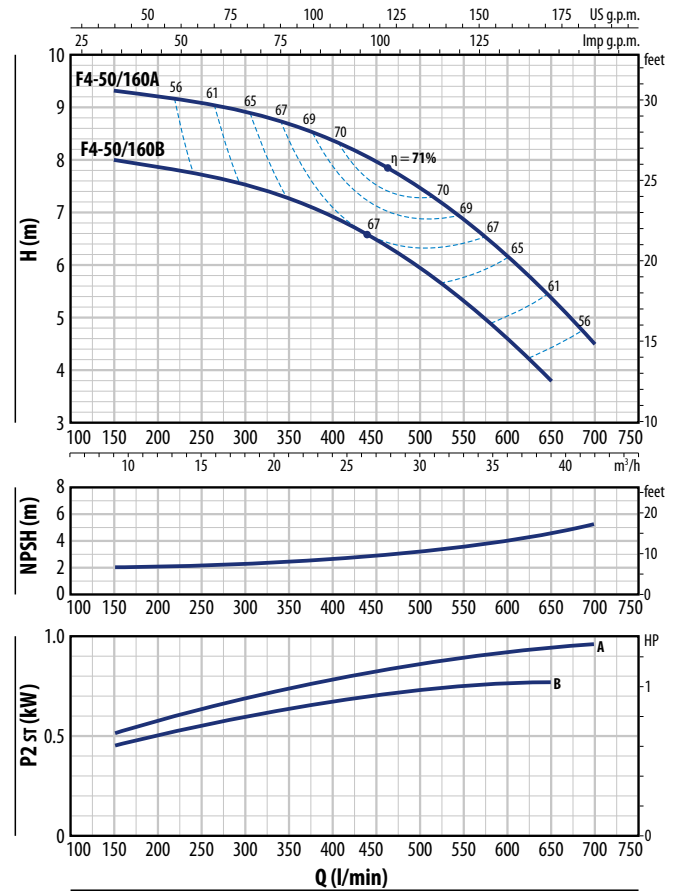

F4-50/125

TYPE	POWER (P ₂)		3~	Q	m ³ /h												
	kW	HP			9	12	15	17	21	24	27	30	33	36			
Three-phase				l/min	150	200	250	300	350	400	450	500	550	600			
F4-50/125B	0.55	0.75	IE3	H m	5	5	4.9	4.7	4.5	4.2	3.8	3.3	2.7	2			
F4-50/125A	0.55	0.75			6	5.9	5.8	5.6	5.4	5.1	4.7	4.2	3.7	3			

F4-50/160

TYPE	POWER (P ₂)		3~	Q	m ³ /h													
	kW	HP			9	12	15	17	21	24	27	30	33	36	39	42		
Three-phase				l/min	150	200	250	300	350	400	450	500	550	600	650	700		
F4-50/160B	0.75	1	IE3	H m	8	7.8	7.7	7.5	7.2	6.9	6.5	5.9	5.3	4.6	3.8			
F4-50/160A	1.1	1.5			9.3	9.2	9.1	8.9	8.7	8.4	8	7.4	6.8	6.2	5.4	4.5		

Q = Flow rate H = Total manometric head HS = Suction height

Performance curves comply with EN ISO 9906 Grade 3B tolerance limits.

F4-50/200

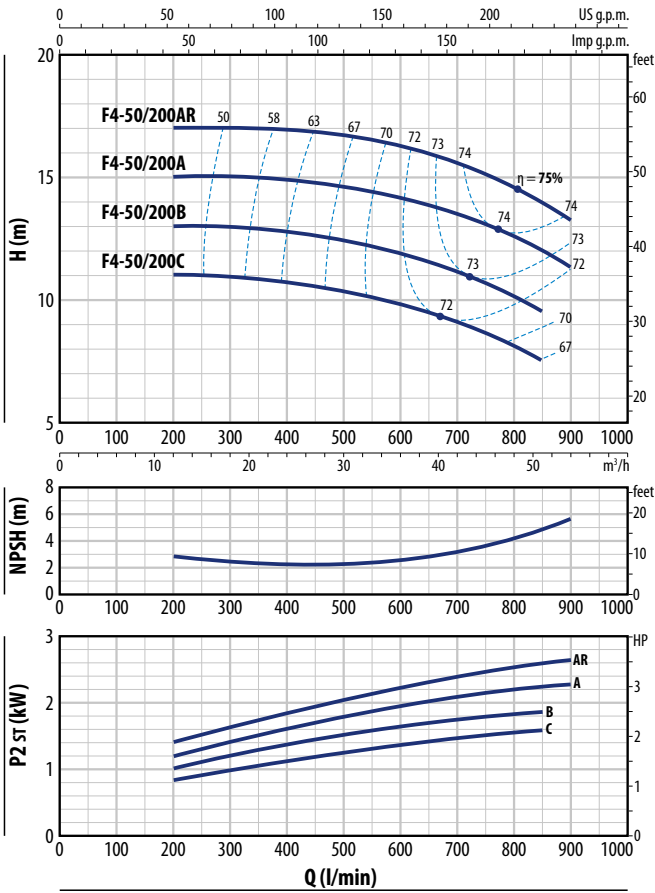

F4-50/250

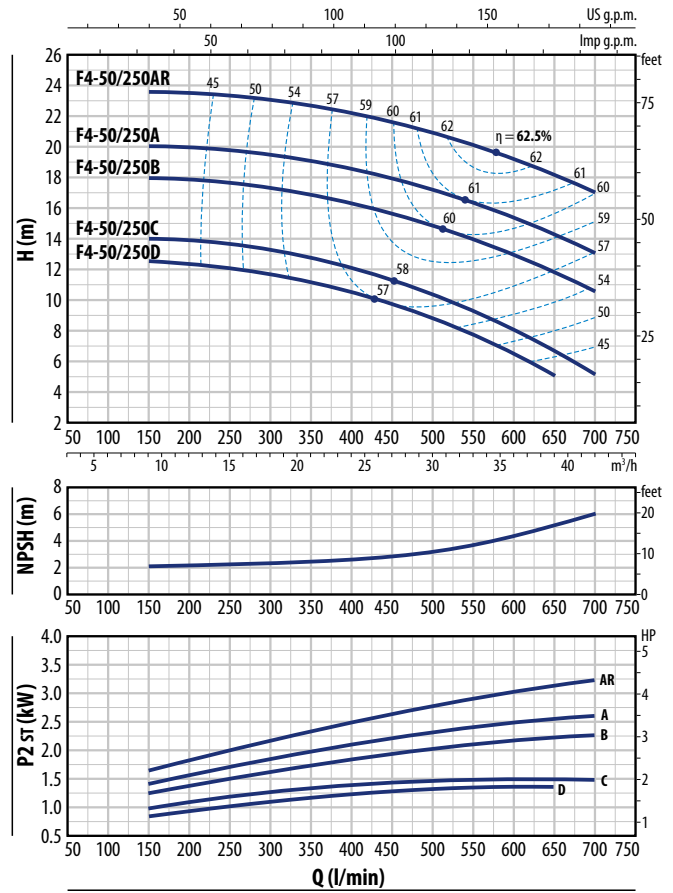

F4-50/200

TYPE	POWER (P ₂)		3~	Q	m ³ /h												
	kW	HP			12	17	24	30	36	42	48	51	54				
Three-phase				l/min	200	300	400	500	600	700	800	850	900				
F4-50/200C	1.5	2	IE3	H m	11	11	10.8	10.3	9.8	9	8	7.5					
F4-50/200B	2.2	3			13	13	12.8	12.4	11.9	11.1	10.1	9.5					
F4-50/200A	2.2	3			15	15	14.9	14.6	14.1	13.5	12.5	12	11.2				
F4-50/200AR	3	4			17	17	16.9	16.7	16.2	15.5	14.5	14	13.2				

F4-50/250

TYPE	POWER (P ₂)		3~	Q	m ³ /h													
	kW	HP			9	12	15	18	21	24	27	30	33	36	39	42		
Three-phase				l/min	150	200	250	300	350	400	450	500	550	600	650	700		
F4-50/250D	1.1	1.5	IE3	H m	12.5	12.3	12	11.5	11.1	10.5	9.8	8.8	7.8	6.5	5			
F4-50/250C	1.5	2			14	13.9	13.6	13.2	12.8	12	11.2	10.2	9.2	8	6.6	5		
F4-50/250B	2.2	3			18	17.9	17.6	17.2	16.8	16.2	15.5	14.8	14	13	11.8	10.5		
F4-50/250A	2.2	3			20	19.9	19.7	19.5	19	18.5	18	17.2	16.2	15.3	14.2	13		
F4-50/250AR	3	4			23.5	23.4	23.2	23	22.6	22.1	21.6	21	20	19	18	17		

Q = Flow rate H = Total manometric head HS = Suction height

Performance curves comply with EN ISO 9906 Grade 3B tolerance limits.

F4-65

CURVES AND PERFORMANCE DATA – n= 1750 min⁻¹

HS= 0 m 60 Hz

F4-65/125

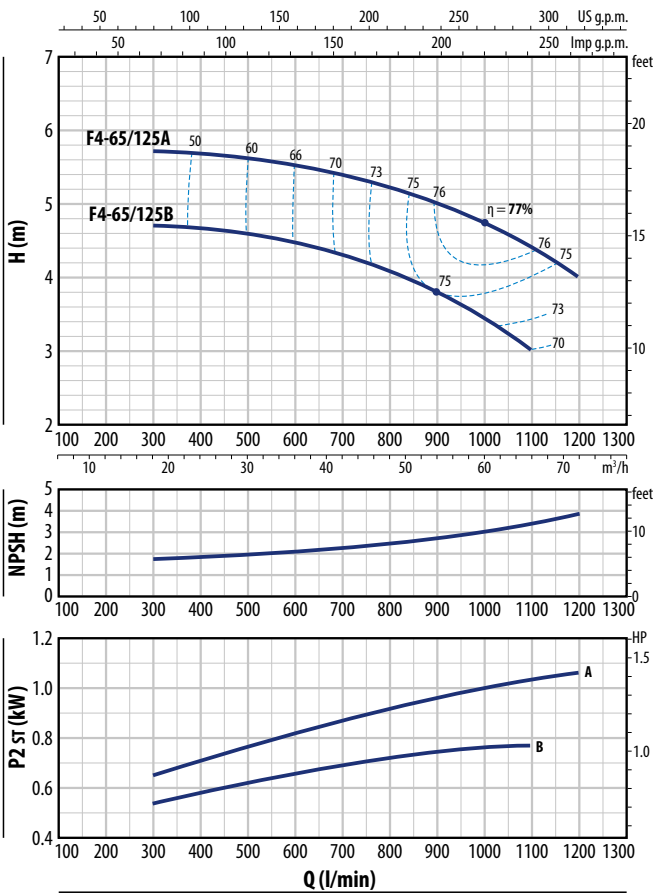

F4-65/160

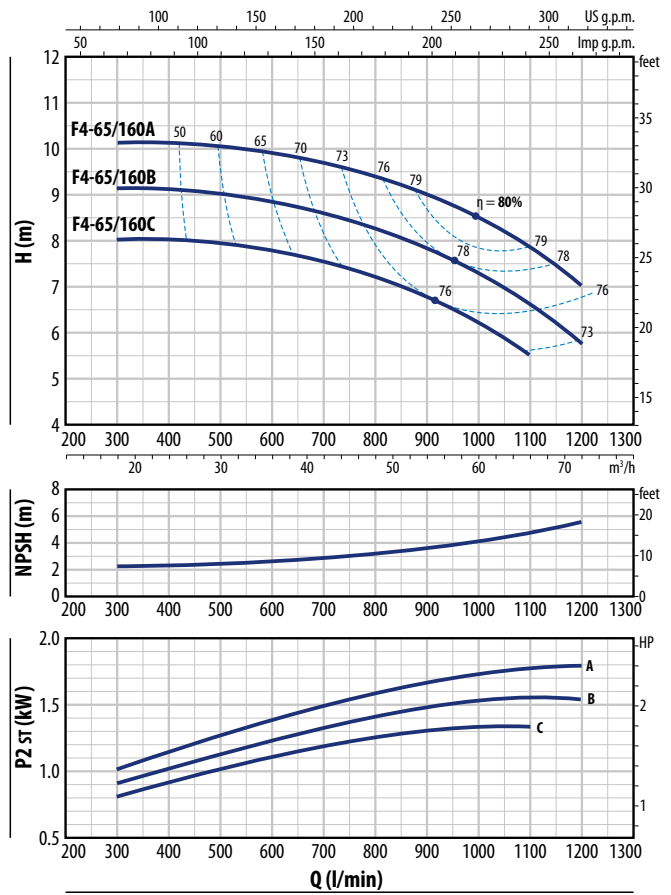

F4-65/125

TYPE	POWER (P ₂)		3~	Q	m ³ /h													
	kW	HP			18	24	30	36	42	48	54	60	66	72				
Three-phase				l/min	300	400	500	600	700	800	900	1000	1100	1200				
F4-65/125B	0.75	1	IE3	H m	4.7	4.7	4.6	4.5	4.3	4.1	3.8	3.4	3					
F4-65/125A	1.1	1.5			5.7	5.7	5.6	5.5	5.4	5.2	5	4.7	4.4	4				

F4-65/160

TYPE	POWER (P ₂)		3~	Q	m ³ /h													
	kW	HP			18	24	30	36	42	48	54	60	66	72				
Three-phase				l/min	300	400	500	600	700	800	900	1000	1100	1200				
F4-65/160C	1.1	1.5	IE3	H m	8	8	7.9	7.7	7.5	7.2	6.7	6.2	5.5					
F4-65/160B	1.5	2			9.1	9.1	9	8.8	8.6	8.3	7.8	7.3	6.6	5.7				
F4-65/160A	2.2	3			10.1	10.1	10.1	9.9	9.7	9.4	9	8.5	7.8	7				

Q = Flow rate H = Total manometric head HS = Suction height

Performance curves comply with EN ISO 9906 Grade 3B tolerance limits.

CURVES AND PERFORMANCE DATA – n= 1750 min⁻¹

HS= 0 m 60 Hz

F4-65/200

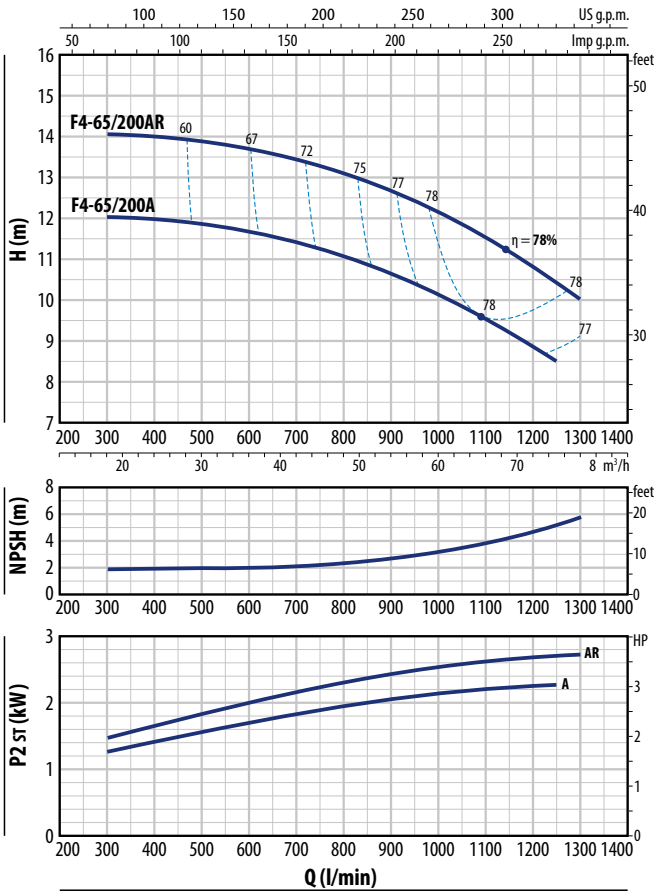

F4-65/250

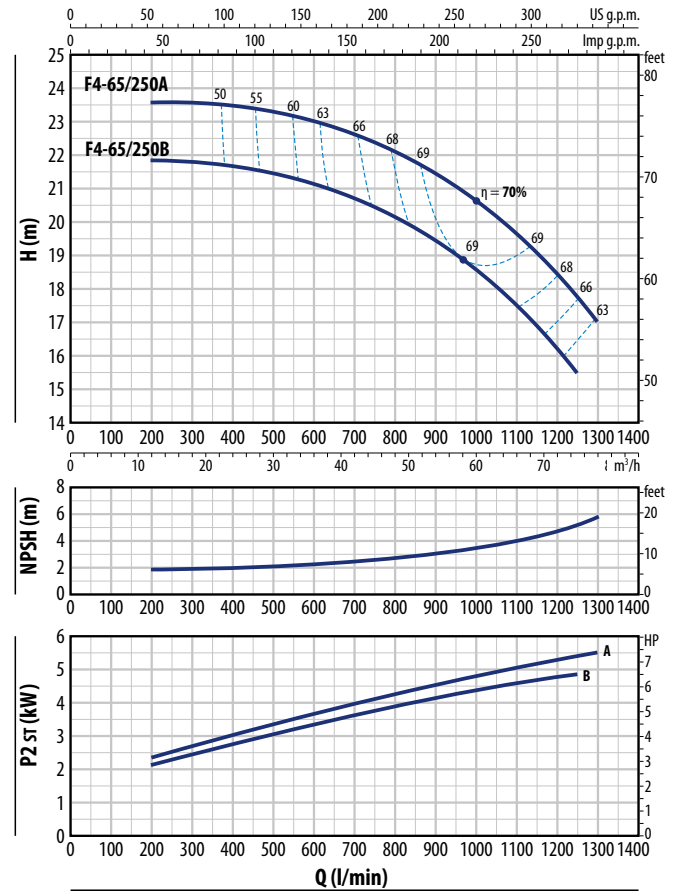

F4-65/200

TYPE	POWER (P ₂)		3~	Q	m ³ /h													
	kW	HP			18	24	30	36	42	48	54	60	66	72	75	78		
Three-phase				l/min	300	400	500	600	700	800	900	1000	1100	1200	1250	1300		
F4-65/200A	2.2	3	IE3	H m	12	12	11.9	11.6	11.4	11	10.6	10.1	9.5	8.8	8.5			
F4-65/200AR	3	4			14	13.9	13.8	13.6	13.4	13.1	12.7	12.1	11.5	10.8	10.3	10		

F4-65/250

TYPE	POWER (P ₂)		3~	Q	m ³ /h													
	kW	HP			12	18	24	30	36	42	48	54	60	66	72	75	78	
Three-phase				l/min	200	300	400	500	600	700	800	900	1000	1100	1200	1250	1300	
F4-65/250B	4	5.5	IE3	H m	21.8	21.8	21.7	21.5	21.2	20.7	20.2	19.5	18.6	17.5	16.2	15.5		
F4-65/250A	5.5	7.5			23.5	23.5	23.5	23.4	23.1	22.6	22.1	21.5	20.5	19.6	18.5	17.8	17	

Q = Flow rate H = Total manometric head HS = Suction height

Performance curves comply with EN ISO 9906 Grade 3B tolerance limits.

F4-80

CURVES AND PERFORMANCE DATA – n = 1750 min⁻¹

HS = 0 m 60 Hz

F4-80/160

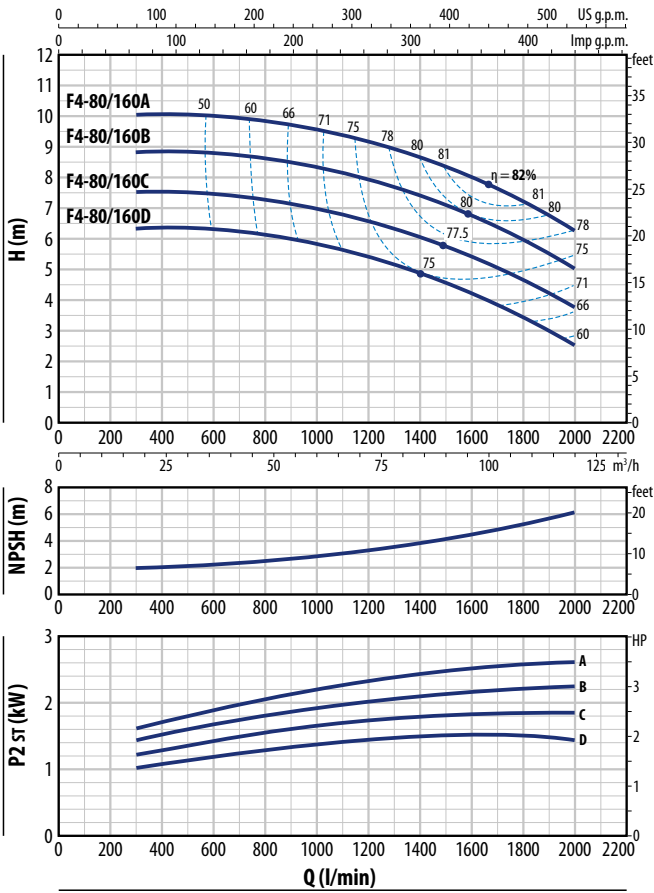

F4-80/200

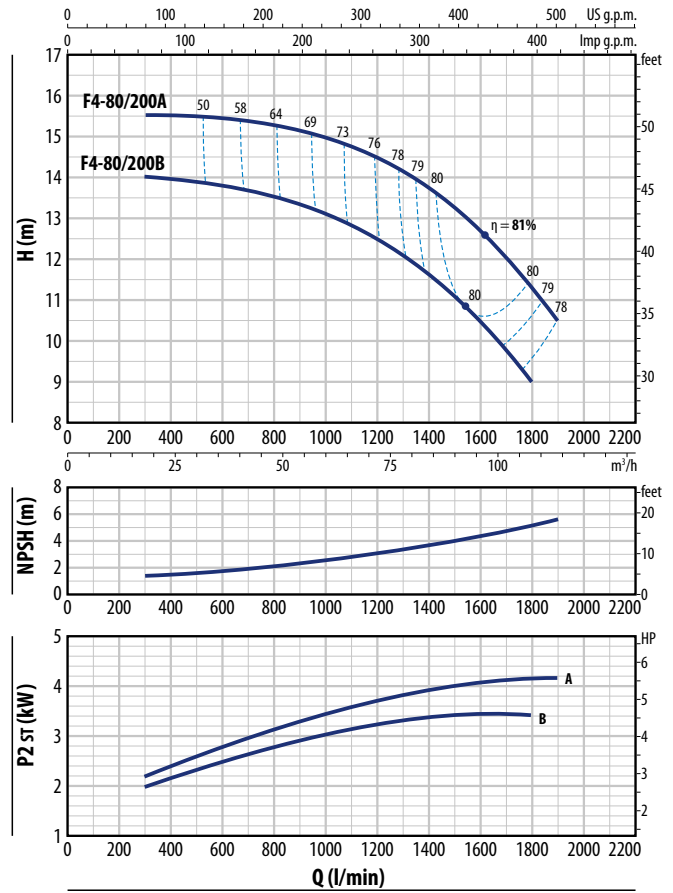

F4-80/160

TYPE	POWER (P ₂)		3~	Q	Flow rate (Q)													
	kW	HP			m ³ /h	l/min	18	24	36	48	60	72	84	96	108	120		
Three-phase	kW	HP			300	400	600	800	1000	1200	1400	1600	1800	2000				
F4-80/160D	1.5	2	IE3	H m	6.3	6.3	6.3	6.1	5.8	5.4	4.8	4.2	3.4	2.5				
F4-80/160C	2.2	3			7.5	7.5	7.4	7.3	6.9	6.5	6	5.4	4.6	3.8				
F4-80/160B	2.2	3			8.8	8.8	8.8	8.6	8.3	7.9	7.4	6.7	5.9	5				
F4-80/160A	3	4			10	10	10	9.8	9.5	9.1	8.6	8	7.2	6.2				

F4-80/200

TYPE	POWER (P ₂)		3~	Q	Flow rate (Q)										
	kW	HP			m ³ /h	l/min	18	24	36	48	60	72	84	96	108
Three-phase	kW	HP			300	400	600	800	1000	1200	1400	1600	1800	1900	
F4-80/200B	4	5.5	IE3	H m	14	13.9	13.7	13.4	13	12.5	11.7	10.6	9		
F4-80/200A	5.5	7.5			15.5	15.5	15.4	15.2	14.8	14.5	13.7	12.8	11.5	10.5	

Q = Flow rate H = Total manometric head HS = Suction height

Performance curves comply with EN ISO 9906 Grade 3B tolerance limits.

F4-80/250

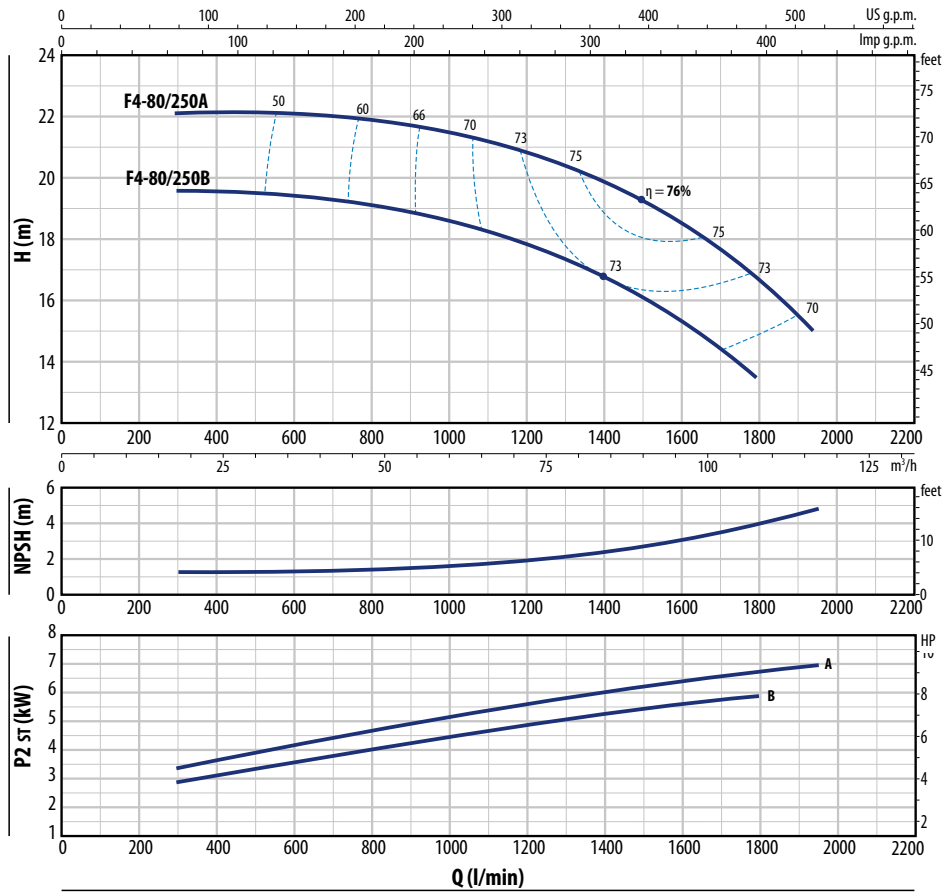

F4-80/250

TYPE	POWER (P ₂)		3~	Q	Flow Rate (Q)													
	kW	HP			m ³ /h	l/min	18	24	36	48	60	72	84	96	108	117		
Three-phase					300	400	600	800	1000	1200	1400	1600	1800	1950				
F4-80/250B	5.5	7.5	IE3	H m	19.5	19.5	19.5	19.2	18.7	17.9	16.7	15.3	13.5					
F4-80/250A	7.5	10			22	22	22	21.9	21.6	21	20	18.5	16.5	15				

Q = Flow rate H = Total manometric head HS = Suction height

Performance curves comply with EN ISO 9906 Grade 3B tolerance limits.

F4-100

CURVES AND PERFORMANCE DATA – n= 1750 min⁻¹

HS= 0 m 60 Hz

F4-100/160

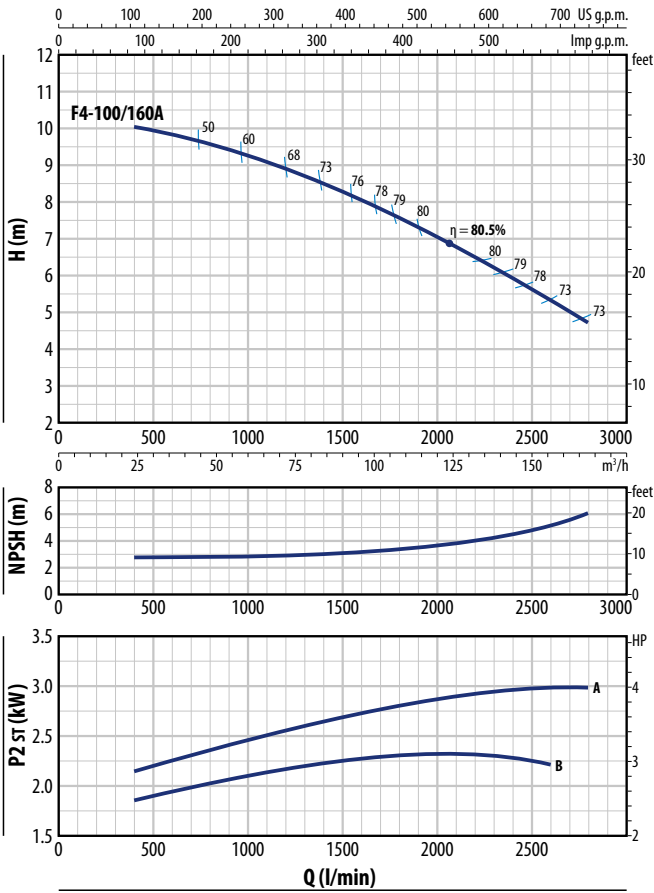

F4-100/200

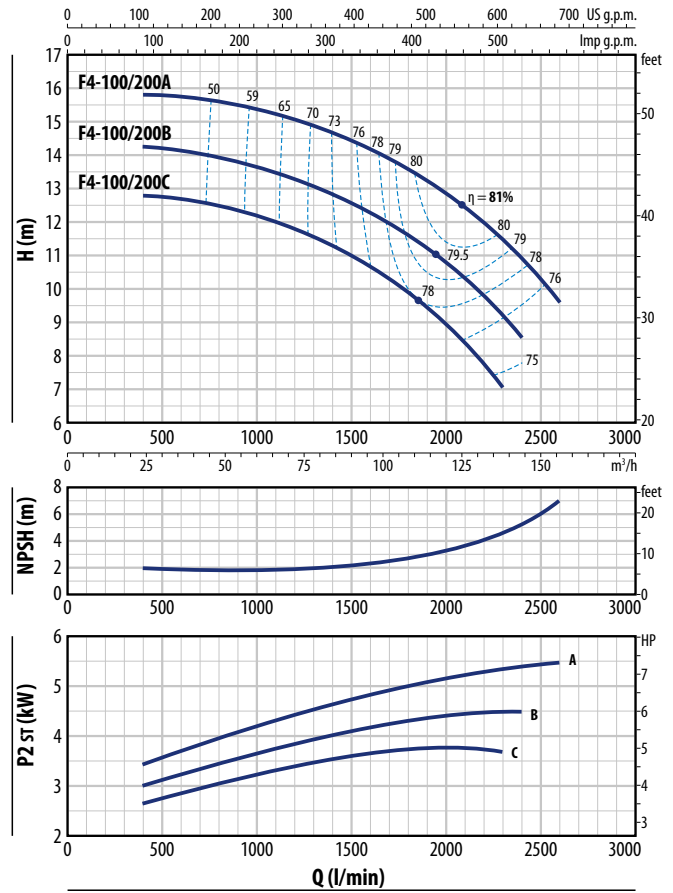

F4-100/160

TYPE	POWER (P ₂)		3~	Q	Q										
	kW	HP			m ³ /h	24	48	72	96	120	144	156	168		
Three-phase				l/min	400	800	1200	1600	2000	2400	2600	2800			
F4-100/160A	3	4	IE3	H m	10	9.5	9	8	7	6	5.2	4.7			

F4-100/200

TYPE	POWER (P ₂)		3~	Q	Q														
	kW	HP			m ³ /h	24	36	48	60	72	84	96	108	120	138	144	156		
Three-phase				l/min	400	600	800	1000	1200	1400	1600	1800	2000	2300	2400	2600			
F4-100/200C	4	5.5	IE3	H m	12.7	12.6	12.5	12.2	11.8	11.3	10.6	9.9	8.9	7					
F4-100/200B	5.5	7.5			14.2	14.1	13.9	13.6	13.3	12.8	12.2	11.6	10.7	9.2	8.5				
F4-100/200A	5.5	7.5			15.8	15.7	15.6	15.4	15	14.6	14.2	13.5	12.8	12	11.4	9.5			

Q = Flow rate H = Total manometric head HS = Suction height

Performance curves comply with EN ISO 9906 Grade 3B tolerance limits.

F4-100/250

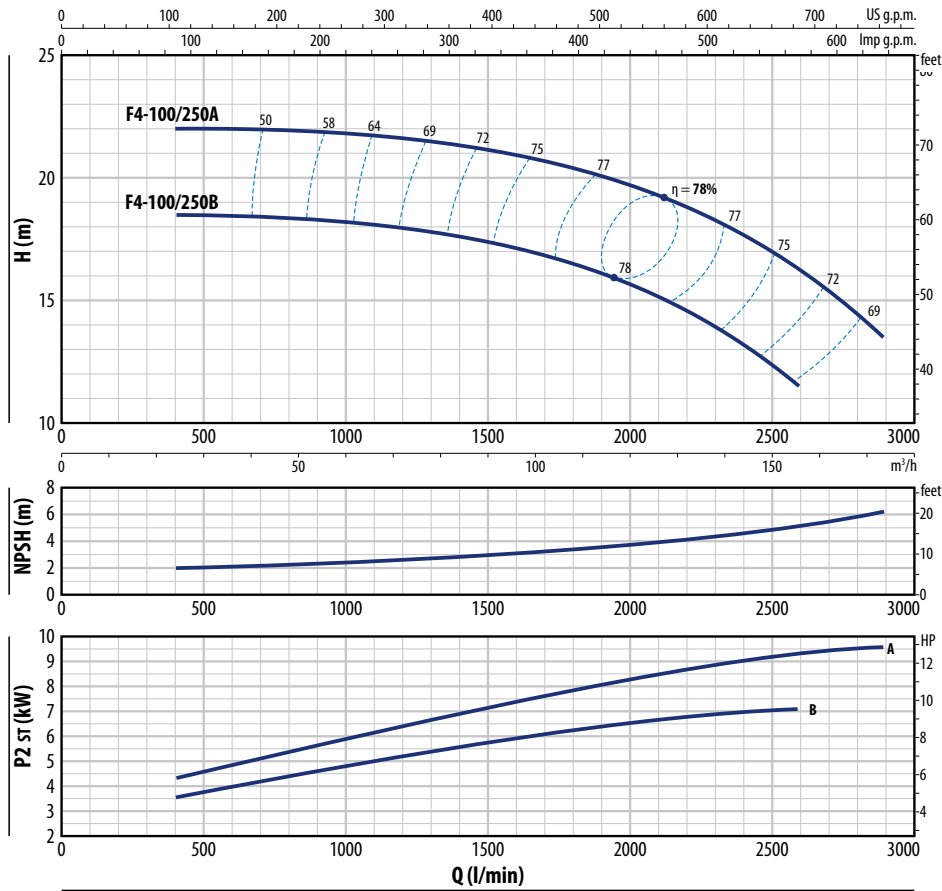

F4-100/250

TYPE	POWER (P ₂)		3~	Q	m ³ /h													
	kW	HP			24	36	48	60	72	84	96	108	120	132	144	156	174	
Three-phase				l/min	400	600	800	1000	1200	1400	1600	1800	2000	2200	2400	2600	2900	
F4-100/250B	7.5	10	IE3	H m	18.5	18.5	18.3	18.2	18	17.5	17.1	16.5	15.7	14.5	13.2	11.5		
F4-100/250A	9.2	12.5			22	22	22	21.8	21.6	21.2	20.9	20.3	19.7	18.9	17.9	16.5	13.5	

Q = Flow rate H = Total manometric head HS = Suction height

Performance curves comply with EN ISO 9906 Grade 3B tolerance limits.

F4

DIMENSIONS AND WEIGHT

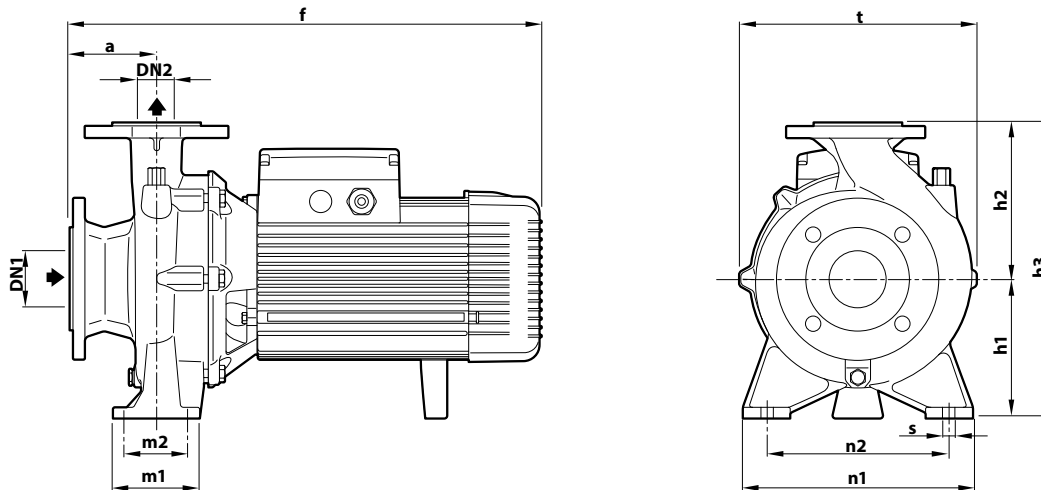

TYPE	PORTS		DIMENSIONS mm											kg						
	DN1	DN2	a	f	h3	h1	h2	t	n2	n1	m1	m2	s							
Three-phase																				
F4-32/160B	50	32	80	412	292	132	160	242	190	240	100	70	14	31.2						
F4-32/160A																	31.2			
F4-32/200B																	43.0			
F4-32/200A					100	478	340	160	180	270	250	320		95		43.5				
F4-32/200BH																	37.9			
F4-32/200AH																		42.4		
F4-32/250C						531	405	180	225	330	250	320		125	95		64.1			
F4-32/250B																		63.1		
F4-32/250A						581													68.7	
F4-40/160B	65	40	80	412	292	132	160	240	190	240	100	70	14	32.5						
F4-40/160A																	32.9			
F4-40/200B					100	498	340	160	180	275	212	265				46.0				
F4-40/200A																46.2				
F4-40/250C							531	405	180	225	328	250		320	125	95	60.1			
F4-40/250B																	60.1			
F4-40/250A				581										72.4						
F4-50/125B	65	50	100	431	292	132	160	242	190	240	100	70	14	32.2						
F4-50/125A																		32.2		
F4-50/160B							498	340		180				269	212	265			44.4	
F4-50/160A																				44.6
F4-50/200C							538		160										59.2	
F4-50/200B																			68.3	
F4-50/200A						589	360		200	316						68.5				
F4-50/200AR																68.8				
F4-50/250D						531											59.9			
F4-50/250C																	63.3			
F4-50/250B							405	180	225	337	250	320		125	95		68.7			
F4-50/250A						581											69.1			
F4-50/250AR														78.0						
F4-65/125B	80	65	100	520	340		180	291	212	280	125	95	14	50.2						
F4-65/125A																				50.4
F4-65/160C							542	360						160	200	300				
F4-65/160B																			58.7	
F4-65/160A							592												65.0	
F4-65/200A																			72.0	
F4-65/200AR							595	405	180	225				340	250	320				78.4
F4-65/250B																				111.2
F4-65/250A							680	450	200	250				373	280	360	160	120	18	139.6

DIMENSIONS AND WEIGHT

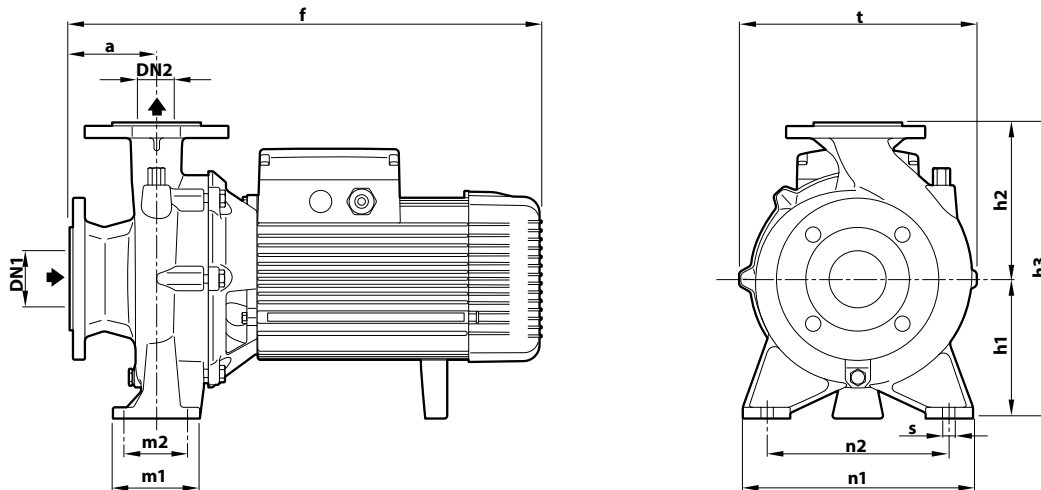

TYPE	PORTS		DIMENSIONS mm											kg								
	DN1	DN2	a	f	h3	h1	h2	t	n2	n1	m1	m2	s									
Three-phase																						
F4-80/160D	100	80	125	574	405	180	225	330	250	320	125	95	14	66.0								
F4-80/160C				624										67.3								
F4-80/160B				624										70.0								
F4-80/160A				624										76.4								
F4-80/200B				709	430									250	360	280	345	100.0				
F4-80/200A				709	430									250	360	280	345	130.2				
F4-80/250B				727	480									200	280	405	315	400	160	120	18	123.0
F4-80/250A				727	480									200	280	405	315	400	160	120	18	137.6
F4-100/160B	125	100	125	638	480	200	280	362	280	360	160	120	18	96.2								
F4-100/160A				711										97.0								
F4-100/200C				711										124.1								
F4-100/200B				711	116.0																	
F4-100/200A				711	122.0																	
F4-100/250B				140	747									505	225	422	315	400	143.0			
F4-100/250A	140	747	505	225	422	315	400	156.0														

PORT FLANGES

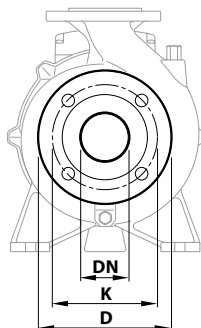

COUNTER-FLANGE

(CAN BE ORDERED SEPARATELY)

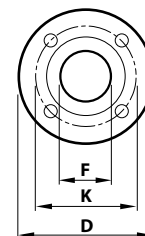

DN FLANGE mm	D mm	K mm	HOLES	
			N°	Ø (mm)
32	140	100	4	18
40	150	110		
50	165	125		
65	185	145		
80	200	160	8	18
100	220	180		
125	250	210		

DN FLANGE mm	F COUNTER-FLANGE	D mm	K mm	HOLES	
				N°	Ø (mm)
32	1¼"	140	100	4	18
40	1½"	150	110		
50	2"	165	125		
65	2½"	185	145		
80	3"	200	160	8	18
100	4"	220	180		
125	5"	250	210		

F4

ABSORPTION

TYPE	VOLTAGE	
	220 V - Δ	380 V - Y
Three-phase		
F4-32/160B	1.9 A	1.1 A
F4-32/160A	2.3 A	1.3 A
F4-32/200B	3.6 A	2.1 A
F4-32/200A	4.0 A	2.3 A
F4-32/200BH	3.1 A	1.8 A
F4-32/200AH	3.5 A	2.0 A
F4-32/250C	4.5 A	2.6 A
F4-32/250B	5.7 A	3.3 A
F4-32/250A	9.0 A	5.2 A
F4-40/160B	2.1 A	1.2 A
F4-40/160A	2.8 A	1.6 A
F4-40/200B	3.6 A	2.1 A
F4-40/200A	4.2 A	2.4 A
F4-40/250C	4.5 A	2.6 A
F4-40/250B	6.1 A	3.5 A
F4-40/250A	9.0 A	5.2 A
F4-50/125B	2.4 A	1.4 A
F4-50/125A	2.6 A	1.5 A
F4-50/160B	3.6 A	2.1 A
F4-50/160A	4.3 A	2.5 A
F4-50/200C	6.1 A	3.5 A
F4-50/200B	8.0 A	4.6 A
F4-50/200A	9.0 A	5.2 A
F4-50/200AR	11.8 A	6.8 A
F4-50/250D	4.5 A	2.6 A
F4-50/250C	5.9 A	3.4 A
F4-50/250B	8.5 A	4.9 A
F4-50/250A	9.9 A	5.7 A
F4-50/250AR	11.8 A	6.8 A
F4-65/125B	3.6 A	2.1 A
F4-65/125A	4.5 A	2.6 A
F4-65/160C	4.7 A	2.7 A
F4-65/160B	5.9 A	3.4 A
F4-65/160A	7.8 A	4.5 A

TYPE	VOLTAGE	
	220 V - Δ	380 V - Y
Three-phase		
F4-65/200A	9.0 A	5.2 A
F4-65/200AR	11.8 A	6.8 A
F4-65/250B	17.3 A	10.0 A
F4-65/250A	23.4 A	13.5 A
F4-80/160D	5.9 A	3.4 A
F4-80/160C	8.1 A	4.7 A
F4-80/160B	9.2 A	5.3 A
F4-80/160A	11.8 A	6.8 A
F4-80/200B	16.4 A	9.5 A
F4-80/200A	22.2 A	12.8 A
F4-80/250B	23.4 A	13.5 A
F4-80/250A	25.6 A	14.8 A
F4-100/160A	12.1 A	7.0 A
F4-100/200C	16.4 A	9.5 A
F4-100/200B	19.0 A	11.0 A
F4-100/200A	21.6 A	12.5 A
F4-100/250B	27.5 A	15.9 A
F4-100/250A	34.1 A	19.7 A

MATERIALS AND COMPONENTS

1 Pump body	Cast iron, fitted with inlet and outlet flanged ports			
2 Cover	Cast iron			
3 Impeller	Brass	for F4-32/160 - 32/200 - 40/160 - 40/200 - 50/125 - 50/160		
	Cast iron	for F4-32/250 - 40/250 - 50/200 - 50/250 - 65/125 - 65/160 - 65/200 - 65/250 F4-80/160 - 80/200 - 80/250 - 100/160 - 100/200 - 100/250		
4 Mechanical seal	Water pump	Seal	Shaft	Materials
	F4-32/160	FN-20	Ø 20 mm	Graphite / Ceramic / NBR
	F4-40/160			
	F4-50/125			
	F4-32/200	FN-24	Ø 24 mm	Graphite / Ceramic / NBR
	F4-40/200			
	F4-50/160			
	F4-65/125	FN-32 NU	Ø 32 mm	Graphite / Ceramic / NBR
	F4-50/200			
	F4-65/200			
	F4-80/160	FN-38	Ø 38 mm	Graphite / Ceramic / NBR
	F4-100/160			
	F4-32/250			
F4-40/250	FN-40 NU	Ø 40 mm	Graphite / Ceramic / NBR	
F4-50/250				
F4-65/250				
F4-80/200	FN-45 NU	Ø 45 mm	Graphite / Ceramic / NBR	
F4-100/200				
F4-80/250				
F4-100/250				
5 Motor shaft	Stainless steel AISI 431			
6 Electric motor	F4: 4-pole three-phase 220/380 V - 60 Hz			
	※ The pumps are equipped with high-efficiency motors (IEC 60034-30-1) class IE3 Continuous running duty S1			

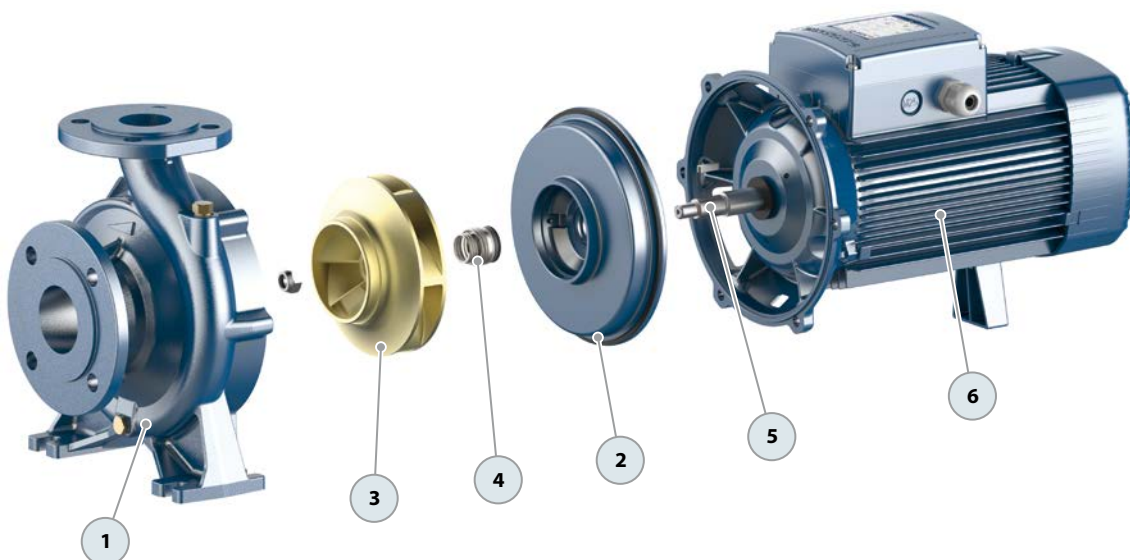

-  Clean water
-  Civil use
-  Industrial use
-  Agricultural use



PERFORMANCE RANGE

- Flow rate up to **5750 l/min** (345 m³/h)
- Head up to **98 m**

INSTALLATION AND USE

Standardized centrifugal pumps equipped with a support structure and built according to EN733 standard.

Designed to transfer clean water free from abrasive particles and liquids that will not damage the pump's components.

- **Water supply**
- **Pressurization**
- **Irrigation**
- **Firefighting systems**
- **Industrial applications**
- **Agriculture applications**
- **Civil, industrial, and agricultural applications**
- **Air conditioning, cooling, heating, and circulation systems**

APPLICATION LIMITS

- Manometric suction head up to **7 m**
- Liquid temperature between **-10 °C** and **+90 °C**
- Maximum pressure in the pump body **10 bar** (PN10)

AVAILABLE UPON REQUEST

- ✘ Mechanical seal options available
- ✘ Pumps for motors with 60 Hz frequency
- ✘ Handling of liquids with higher or lower temperatures
- ✘ Adaptability to operate in high or low temperature environments
- ✘ Counterflange KIT including screws, nuts and gaskets

