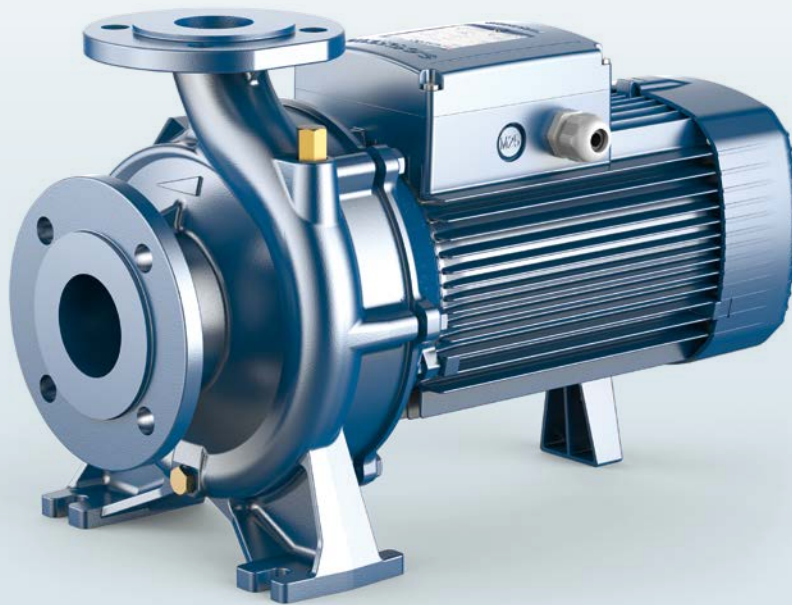

 Aguas limpias

 Uso industrial

### CAMPO DE PRESTACIONES

- Caudal hasta **2900 l/min** (174 m<sup>3</sup>/h)
- Altura hasta **23.8 m**
- Potencia de **0.37 a 9.2 kW**

### USOS E INSTALACIONES

- Para aguas limpias sin partes abrasivas y líquidos químicamente no agresivos los materiales de la bomba.
- Suministro de agua
- Presurización
- Riego
- Circulación de agua en sistemas de aire acondicionado
- Plantas de lavado
- Sistemas contra incendios
- Industria
- Agricultura

La instalación debe realizarse en lugares cerrados bien ventilados o protegidos de la intemperie.

### MOTOR ELÉCTRICO

Las electrobombas trifásicas están equipadas con motores eléctricos de nuevo desarrollo, diseñados para funcionar con variadores, que garantizan un funcionamiento equilibrado y silencioso.

Las clase de eficiencia **IE3** para motores trifásicos, **IE2** para motores monofásicos, aislamiento de clase F y protección IP55.

### LÍMITES DE UTILIZO

- Altura de aspiración manométrica de hasta **7 m**
- Temperatura del líquido de **-10 °C a +90 °C**
- Temperatura ambiente **-10 °C hasta +40 °C**
- Presión máxima en el cuerpo de la bomba **10 bar** (PN10)

### EJECUCIONES A PEDIDO

- ✘ Otras tensiones o frecuencias a 60 Hz
- ✘ Para líquidos con temperaturas más altas o más bajas
- ✘ Para ambientes con temperaturas más altas o más bajas

- ✘ KIT de contrabrida con tornillos, tuercas y juntas



## CAMPO DE PRESTACIONES - n= 1450 min<sup>-1</sup>

50 Hz

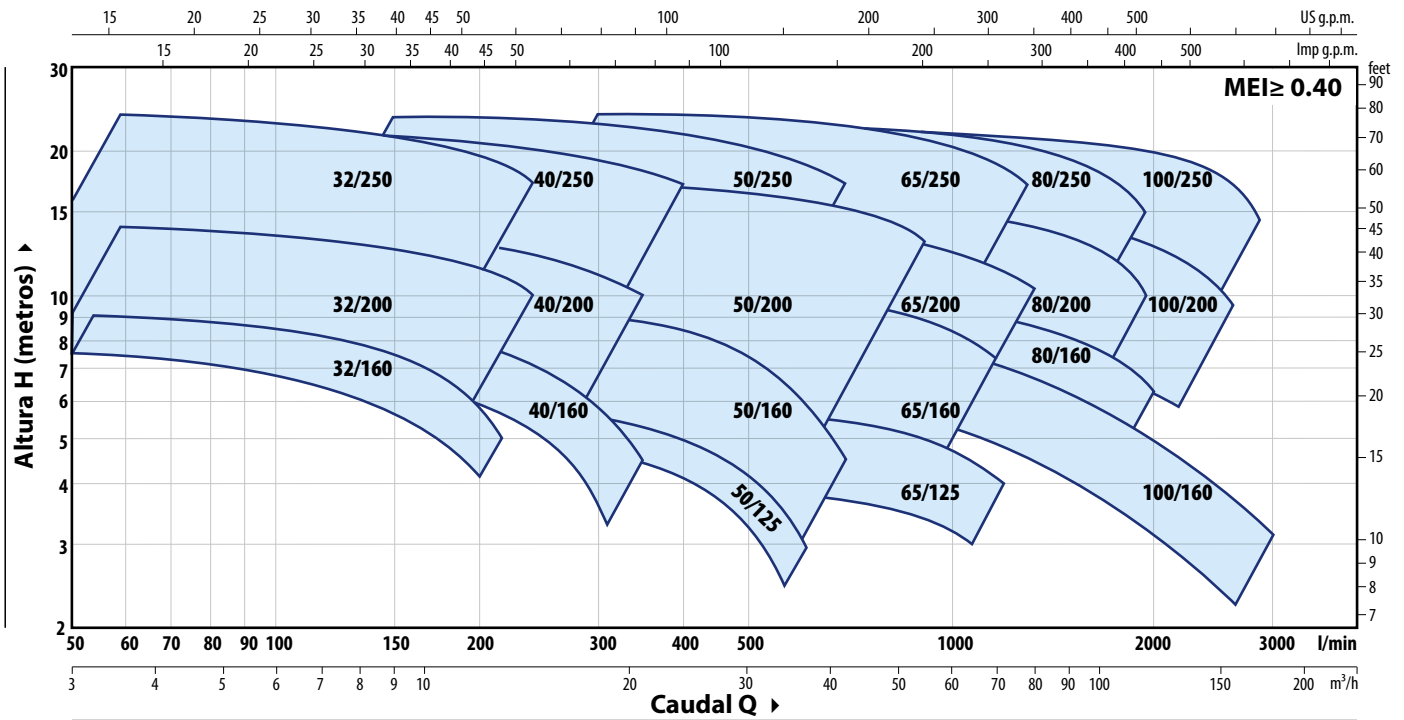

## DATOS DE PRESTACIONES - n= 1450 min<sup>-1</sup>

50 Hz

TIPO	POTENCIA (P <sub>2</sub> )		PRESTACIONES							
	kW	HP	Q	H	Q	H	Q	H	Q	H
Trifásico			l/min	m	l/min	m	l/min	m	l/min	m
F4-32/160B	0.37	0.5	50	7.5	165	5.6	200	4.5		
F4-32/160A	0.37	0.5	50	9	175	6.8	225	5		
F4-32/200B	0.75	1	50	12.5	230	9.5	250	9		
F4-32/200A	1.1	1.5	50	14	240	10.8	250	10.5		
F4-32/200BH	0.75	1	50	11.3	140	9.6	150	9.2		
F4-32/200AH	0.75	1	50	13.8	150	11.5	160	11		
F4-32/250C	1.1	1.5	50	18.4	220	15	220	15		
F4-32/250B	1.5	2	50	21.7	250	17.4	250	17.4		
F4-32/250A	2.2	3	50	23.8	270	18.7	270	18.7		
F4-40/160B	0.37	0.5	50	7.5	220	6.0	320	3.5		
F4-40/160A	0.55	0.75	50	9	245	7.1	350	4.5		
F4-40/200B	0.75	1	50	11.5	280	8.9	350	7		
F4-40/200A	1.1	1.5	50	13.8	310	10.9	350	10		
F4-40/250C	1.1	1.5	50	15.5	320	12.4	400	10		
F4-40/250B	1.5	2	50	17.5	330	14.2	400	12		
F4-40/250A	2.2	3	50	22	380	17.5	400	17		
F4-50/125B	0.55	0.75	150	5	420	4.0	600	2		
F4-50/125A	0.55	0.75	150	6	450	4.8	600	3		
F4-50/160B	0.75	1	150	8	440	6.5	650	3.8		
F4-50/160A	1.1	1.5	150	9.3	460	7.8	700	4.5		
F4-50/200C	1.5	2	200	11	660	9.3	850	7.5		
F4-50/200B	2.2	3	200	13	720	10.9	850	9.5		
F4-50/200A	2.2	3	200	15	770	12.8	900	11.2		
F4-50/200AR	3	4	200	17	800	14.5	900	13.2		
F4-50/250D	1.1	1.5	150	12.5	425	10.1	650	5		
F4-50/250C	1.5	2	150	14	450	11.2	700	5		
F4-50/250B	2.2	3	150	18	510	14.6	700	10.5		
F4-50/250A	2.2	3	150	20	550	16.3	700	13		
F4-50/250AR	3	4	150	23.5	570	19.9	700	17		

TIPO	POTENCIA (P <sub>2</sub> )		PRESTACIONES							
	kW	HP	Q	H	Q	H	Q	H	Q	H
Trifásico			l/min	m	l/min	m	l/min	m	l/min	m
F4-65/125B	0.75	1	300	4.7	900	3.8	1100	3		
F4-65/125A	1.1	1.5	300	5.7	1000	4.7	1200	4		
F4-65/160C	1.1	1.5	300	8	910	6.7	1100	5.5		
F4-65/160B	1.5	2	300	9.1	950	7.6	1200	5.7		
F4-65/160A	2.2	3	300	10.1	990	8.5	1200	7		
F4-65/200A	2.2	3	300	12	1100	9.6	1250	8.5		
F4-65/200AR	3	4	300	14	1140	11.2	1300	10		
F4-65/250B	4	5.5	200	21.8	980	18.8	1250	15.5		
F4-65/250A	5.5	7.5	200	23.5	1000	20.6	1300	17		
F4-80/160D	1.5	2	300	6.3	1400	4.8	2000	2.5		
F4-80/160C	2.2	3	300	7.5	1480	5.7	2000	3.8		
F4-80/160B	2.2	3	300	8.8	1580	6.8	2000	5		
F4-80/160A	3	4	300	10	1660	7.7	2000	6.2		
F4-80/200B	4	5.5	300	14	1540	10.9	1800	9		
F4-80/200A	5.5	7.5	300	15.5	1625	12.6	1900	10.5		
F4-80/250B	5.5	7.5	300	19.5	1500	16.1	1800	13.5		
F4-80/250A	7.5	10	300	22	1400	19.9	1950	15		
F4-100/160B	2.2	3	400	8.3	1950	5.7	2600	3.5		
F4-100/160A	3	4	400	10	2060	6.9	2800	4.7		
F4-100/200C	4	5.5	400	12.7	1850	9.6	2300	7		
F4-100/200B	5.5	7.5	400	14.2	1950	10.9	2400	8.5		
F4-100/200A	5.5	7.5	400	15.8	2050	12.6	2600	9.5		
F4-100/250B	7.5	10	400	18.5	1950	15.9	2600	11.5		
F4-100/250A	9.2	12.5	400	22	2100	19.3	2900	13.5		

Q = Caudal

H = Altura manométrica total

Tolerancia de las curvas de prestaciones según EN ISO 9906 Grado 3B.

# F4 Datos técnicos

## DIMENSIONES Y PESOS

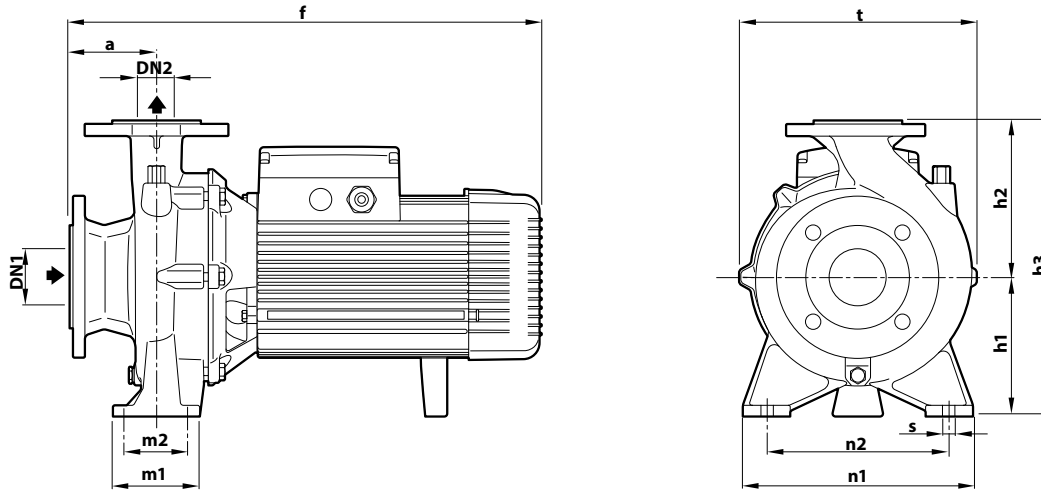

TIPO	BOCAS		DIMENSIONES mm											kg										
	DN1	DN2	a	f	h3	h1	h2	t	n2	n1	m1	m2	s											
<b>Trifásico</b>																								
F4-32/160B	50	32	80	412	292	132	160	242	190	240	100	70	14	31.2										
F4-32/160A																	31.2							
F4-32/200B																			43.0					
F4-32/200A							478	340			160			180	270		95		43.5					
F4-32/200BH																			37.9					
F4-32/200AH															42.4									
F4-32/250C					100	531	405	180	225	330	250	320		125	95	64.1								
F4-32/250B																							63.1	
F4-32/250A						581																		68.7
F4-40/160B			65	40	80	412	292	132	160	240	190	240		100	70	14	32.5							
F4-40/160A																	32.9							
F4-40/200B					100	498	340	160	180	275	212	265			46.0									
F4-40/200A															46.2									
F4-40/250C							531	405	180	225	328	250	320	125	95		60.1							
F4-40/250B																							60.1	
F4-40/250A						581									72.4									
F4-50/125B	65	50	100	431	292	132	160	242	190	240	100	70	14	32.2										
F4-50/125A																		32.2						
F4-50/160B							498	340	160	180				269	212	265			44.4					
F4-50/160A																					44.6			
F4-50/200C							538	360											59.2					
F4-50/200B									200	316						68.3								
F4-50/200A						589										68.5								
F4-50/200AR																68.8								
F4-50/250D						531	405	180	225	337	250	320		125	95	59.9								
F4-50/250C																							63.3	
F4-50/250B																								68.7
F4-50/250A						581																		69.1
F4-50/250AR																78.0								
F4-65/125B			80	65	100	520	340	160	180	291	212	280		125	95	14	50.2							
F4-65/125A																					50.4			
F4-65/160C							542	360		200			300								55.0			
F4-65/160B																					58.7			
F4-65/160A							592														65.0			
F4-65/200A						595	405	180	225	340	250	320			72.0									
F4-65/200AR															78.4									
F4-65/250B						680	450	200	250	373	280	360	160	120	111.2									
F4-65/250A															139.6									

## DIMENSIONES Y PESOS

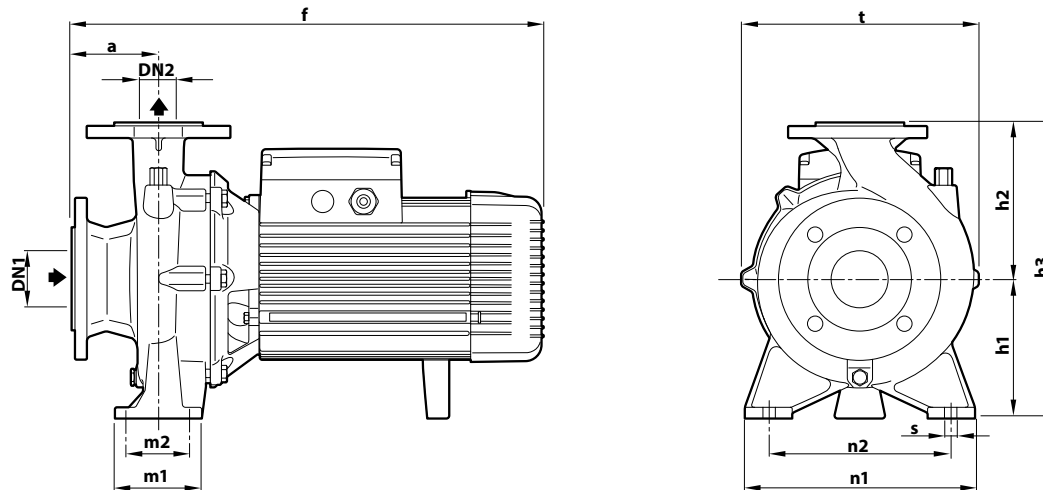

TIPO	BOCAS		DIMENSIONES mm											kg
	DN1	DN2	a	f	h3	h1	h2	t	n2	n1	m1	m2	s	
<b>Trifásico</b>														
<b>F4-80/160D</b>	<b>100</b>	<b>80</b>	125	574	405	180	225	330	250	320	125	95	14	66.0
<b>F4-80/160C</b>				624										67.3
<b>F4-80/160B</b>				624	70.0									
<b>F4-80/160A</b>				624	76.4									
<b>F4-80/200B</b>				709	430	250	360	280	345	100.0				
<b>F4-80/200A</b>				709	430	250	360	280	345	130.2				
<b>F4-80/250B</b>				727	480	200	280	405	315	400	160	120	18	123.0
<b>F4-80/250A</b>				727	480	200	280	405	315	400	160	120	18	137.6
<b>F4-100/160B</b>	<b>125</b>	<b>100</b>	125	638	480	200	280	362	280	360	160	120	18	96.2
<b>F4-100/160A</b>				711										97.0
<b>F4-100/200C</b>				711	124.1									
<b>F4-100/200B</b>				711	116.0									
<b>F4-100/200A</b>				711	122.0									
<b>F4-100/250B</b>				140	747	505	225	422	315	400	143.0			
<b>F4-100/250A</b>	140	747	505	225	422	315	400	156.0						

## BRIDAS DE LAS BOCAS

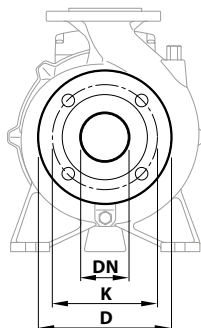

DN BRIDAS mm	D mm	K mm	ORIFICIOS	
			N°	Ø (mm)
<b>32</b>	140	100	4	18
<b>40</b>	150	110		
<b>50</b>	165	125		
<b>65</b>	185	145		
<b>80</b>	200	160	8	18
<b>100</b>	220	180		
<b>125</b>	250	210		

## CONTRABRIDAS

(PUEDE PEDIRSE POR SEPARADO)

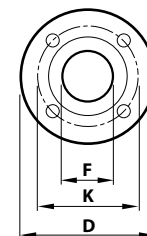

DN BRIDAS mm	F CONTRABRIDAS	D mm	K mm	ORIFICIOS	
				N°	Ø (mm)
<b>32</b>	1¼"	140	100	4	18
<b>40</b>	1½"	150	110		
<b>50</b>	2"	165	125		
<b>65</b>	2½"	185	145		
<b>80</b>	3"	200	160	8	18
<b>100</b>	4"	220	180		
<b>125</b>	5"	250	210		

## CONSUMOS

TIPO	TENSIÓN	
	230 V - $\Delta$	400 V - $\text{Y}$
<b>F4-32/160B</b>	1.9 A	1.1 A
<b>F4-32/160A</b>	2.2 A	1.3 A
<b>F4-32/200B</b>	3.6 A	2.1 A
<b>F4-32/200A</b>	4.0 A	2.3 A
<b>F4-32/200BH</b>	3.3 A	1.9 A
<b>F4-32/200AH</b>	3.5 A	2.0 A
<b>F4-32/250C</b>	5.7 A	3.3 A
<b>F4-32/250B</b>	7.3 A	4.2 A
<b>F4-32/250A</b>	9.5 A	5.5 A
<b>F4-40/160B</b>	1.7 A	1.0 A
<b>F4-40/160A</b>	2.8 A	1.6 A
<b>F4-40/200B</b>	3.6 A	2.1 A
<b>F4-40/200A</b>	4.2 A	2.4 A
<b>F4-40/250C</b>	5.5 A	3.2 A
<b>F4-40/250B</b>	6.1 A	3.5 A
<b>F4-40/250A</b>	9.5 A	5.5 A
<b>F4-50/125B</b>	2.2 A	1.3 A
<b>F4-50/125A</b>	2.6 A	1.5 A
<b>F4-50/160B</b>	3.3 A	1.9 A
<b>F4-50/160A</b>	4.2 A	2.4 A
<b>F4-50/200C</b>	6.1 A	3.5 A
<b>F4-50/200B</b>	8.0 A	4.6 A
<b>F4-50/200A</b>	9.0 A	5.2 A
<b>F4-50/200AR</b>	10.6 A	6.1 A
<b>F4-50/250D</b>	4.8 A	2.8 A
<b>F4-50/250C</b>	5.9 A	3.4 A
<b>F4-50/250B</b>	9.9 A	5.7 A
<b>F4-50/250A</b>	11.1 A	6.4 A
<b>F4-50/250AR</b>	11.8 A	6.8 A
<b>F4-65/125B</b>	3.6 A	2.1 A
<b>F4-65/125A</b>	4.5 A	2.6 A
<b>F4-65/160C</b>	5.2 A	3.0 A
<b>F4-65/160B</b>	5.9 A	3.4 A
<b>F4-65/160A</b>	7.8 A	4.5 A

TIPO	TENSIÓN	
	230 V - $\Delta$	400 V - $\text{Y}$
<b>F4-65/200A</b>	9.0 A	5.2 A
<b>F4-65/200AR</b>	11.8 A	6.8 A
<b>F4-65/250B</b>	17.3 A	10.0 A
<b>F4-65/250A</b>	21.7 A	13.5 A
<b>F4-80/160D</b>	5.9 A	3.4 A
<b>F4-80/160C</b>	10.0 A	5.8 A
<b>F4-80/160B</b>	10.2 A	5.9 A
<b>F4-80/160A</b>	10.6 A	6.1 A
<b>F4-80/200B</b>	13.8 A	8.0 A
<b>F4-80/200A</b>	18.2 A	10.5 A
<b>F4-80/250B</b>	20.8 A	12.5 A
<b>F4-80/250A</b>	25.6 A	14.8 A
<b>F4-100/160B</b>	9.0 A	5.2 A
<b>F4-100/160A</b>	13.0 A	7.5 A
<b>F4-100/200C</b>	14.2 A	8.2 A
<b>F4-100/200B</b>	17.8 A	10.3 A
<b>F4-100/200A</b>	20.8 A	12.0 A
<b>F4-100/250B</b>	26.8 A	15.5 A
<b>F4-100/250A</b>	34.1 A	19.7 A

## CARACTERÍSTICAS CONSTRUCTIVAS

<b>1</b>	<b>Cuerpo de la bomba</b>	Hierro fundido, equipado con bocas de aspiración y de impulsión roscadas			
<b>2</b>	<b>Tapa</b>	Hierro fundido			
<b>3</b>	<b>Rodete</b>	Latón para F4-32/160 - 32/200 - 40/160 - 40/200 - 50/125 - 50/160			
<b>3</b>	<b>Rodete</b>	Hierro fundido para F4-32/250 - 40/250 - 50/200 - 50/250 - 65/125 - 65/160 - 65/200 - 65/250 F4-80/160 - 80/200 - 80/250 - 100/160 - 100/200 - 100/250			
<b>4</b>	<b>Sello mecánico</b>	Electrobomba	Sello	Eje	Materiales
		F4-32/160			
		F4-40/160	<b>FN-20</b>	Ø 20 mm	Grafito / Cerámica / NBR
		F4-50/125			
		F4-32/200			
		F4-40/200	<b>FN-24</b>	Ø 24 mm	Grafito / Cerámica / NBR
		F4-50/160			
		F4-65/125			
		F4-50/200			
		F4-65/200	<b>FN-32 NU</b>	Ø 32 mm	Grafito / Cerámica / NBR
		F4-65/160			
		F4-80/160			
		F4-100/160			
		F4-32/250			
		F4-40/250	<b>FN-38</b>	Ø 38 mm	Grafito / Cerámica / NBR
		F4-50/250			
		F4-65/250			
		F4-80/200	<b>FN-40 NU</b>	Ø 40 mm	Grafito / Cerámica / NBR
		F4-100/200			
		F4-80/250	<b>FH-45 NU</b>	Ø 45 mm	Grafito / Cerámica / NBR
		F4-100/250			
<b>5</b>	<b>Eje motor</b>	Acero inoxidable <b>AISI 431</b>			
<b>6</b>	<b>Motor eléctrico</b>	<b>F4:</b> a 4 polos trifásico 230/400 V - 50 Hz			
		✳ Las electrobombas están equipadas con motores de alto rendimiento (IEC 60034-30-1) clase <b>IE3</b> Servicio continuo <b>S1</b>			

