

-  Acque pulite
-  Uso domestico
-  Uso agricolo
-  Uso industriale

※ **Pompe centrifughe completamente in acciaio inox**



CP-ST4

- ※ Corpo pompa: **acciaio inox AISI 304**
- ※ Girante: **acciaio inox AISI 304**
- ※ Albero: **acciaio inox AISI 431**

CP-ST6

- ※ Corpo pompa: **acciaio inox AISI 316L**
- ※ Girante: **acciaio inox AISI 316L**
- ※ Albero: **acciaio inox AISI 316L**

CAMPO DELLE PRESTAZIONI

- Portata fino a **270 l/min** (16.2 m³/h)
- Prevalenza fino a **45 m**

UTILIZZI E INSTALLAZIONI

Sono consigliate per pompare acqua pulita e liquidi chimicamente non aggressivi per i materiali costituenti la pompa.

Per le caratteristiche costruttive, queste pompe centrifughe sono consigliate per l'utilizzo nel settore domestico, agricolo ed industriale.

Tutti i componenti a contatto con il liquido pompato sono in acciaio inox AISI 304 o AISI 316L a garanzia di una igiene totale e di una massima resistenza alla corrosione.

MOTORE ELETTRICO

Le elettropompe trifase sono equipaggiate con motori elettrici di nuova concezione, progettati per lavorare con inverter, che garantiscono un funzionamento equilibrato e silenzioso.

Classe di efficienza **IE3** per motori trifase, **IE2** per i motori monofase, isolamento in classe F e protezione IPX4.

LIMITI D'IMPIEGO

- Altezza d'aspirazione manometrica fino a **7 m**
- Temperatura del liquido da **-10 °C** fino a **+90 °C**
- Temperatura ambiente fino a **+40 °C**
- Pressione massima nel corpo pompa:
 - **6 bar** per CP 100-130-132-150-158 ST4
CP 100-130-132-150-158 ST6
 - **8 bar** per CP 170-170M ST4
CP 170-170M ST6
CP 180-190-200 ST4
CP 180-190-200 ST6

ESECUZIONI A RICHIESTA

- ※ Tenuta meccanica speciale
- ※ Protezione IP X5 per CP 170-170M-180-190-200 ST
- ※ Altre tensioni o frequenza a 60 Hz
- ※ Elettropompe certificate 

CURVE E DATI DI PRESTAZIONE - HS=0 m

50 Hz

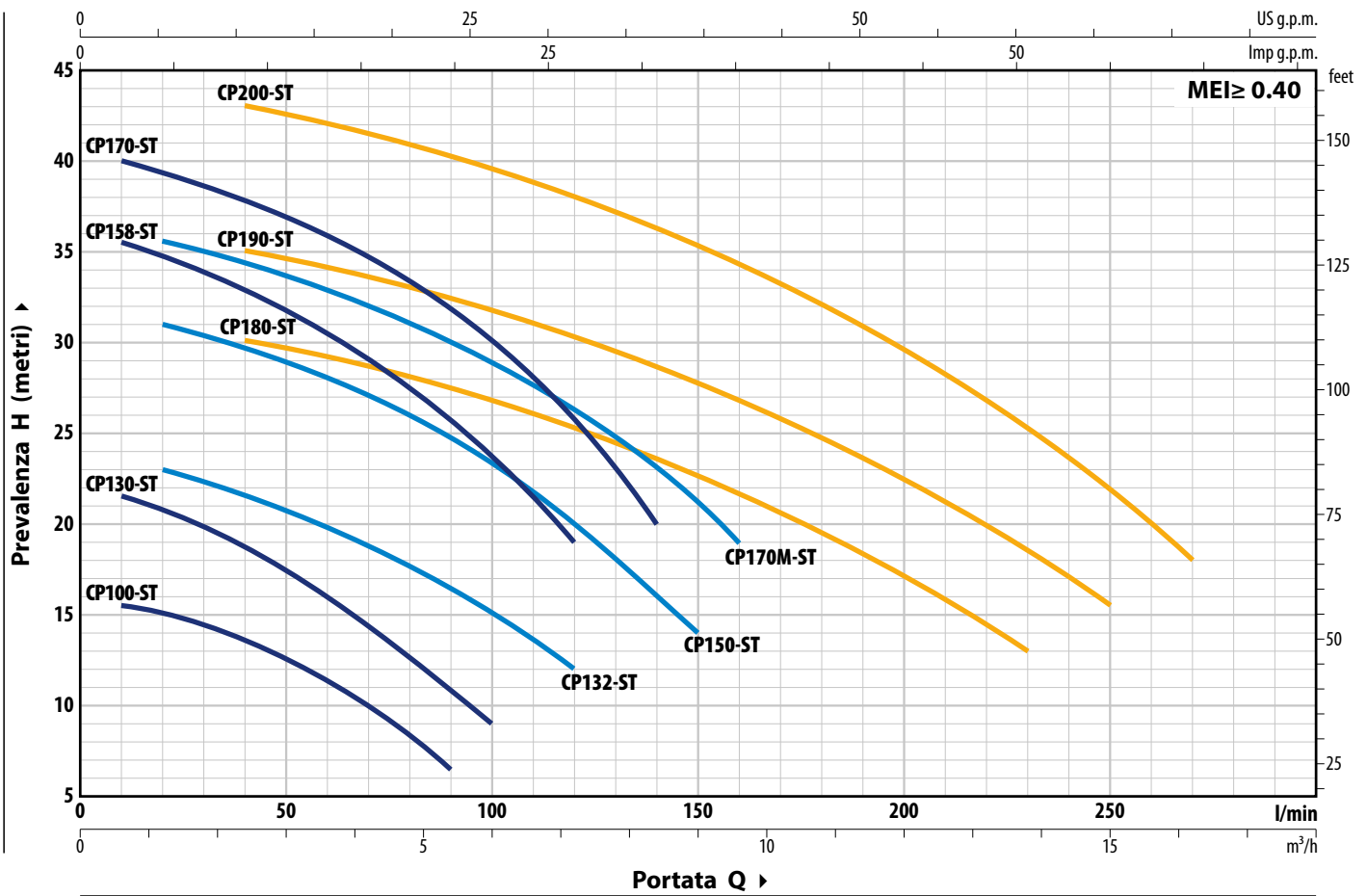

TIPO		POTENZA (P ₂)		Q	m ³ /h																					
Monofase	Trifase	kW	HP		1~	3~	Q	0	0.6	1.2	2.4	3.6	5.4	6.0	7.2	8.4	9.0	9.6	12	13.8	15	16.2				
						l/min	0	10	20	40	60	90	100	120	140	150	160	200	230	250	270					
CPm 100-ST4	CP 100-ST4	0.25	0.33	IE2	IE3	H metri	16	15.5	15	13.5	11.2	6.5														
CPm 100-ST6	CP 100-ST6																									
CPm 130-ST4	CP 130-ST4	0.37	0.50							22.5	21.5	20.8	18.8	16	10.8	9										
CPm 130-ST6	CP 130-ST6																									
CPm 132-ST4	CP 132-ST4	0.55	0.75							24	-	23	21.5	19.8	16.5	15	12									
CPm 132-ST6	CP 132-ST6																									
CPm 150-ST4	CP 150-ST4	0.75	1							32	-	31	29.8	28	24.8	23.2	20	16	14							
CPm 150-ST6	CP 150-ST6																									
CPm 158-ST4	CP 158-ST4	0.75	1							36.5	35.5	34.5	33	31	26.2	24	19									
CPm 158-ST6	CP 158-ST6																									
CPm 170-ST4	CP 170-ST4	1.1	1.5							41	40	39.2	37.8	36	32	30	25.8	20								
CPm 170-ST6	CP 170-ST6																									
CPm 170M-ST4	CP 170M-ST4	1.1	1.5							36.5	-	35.5	34.3	33	30	29	26.4	23	21	19						
CPm 170M-ST6	CP 170M-ST6																									
CPm 180-ST4	CP 180-ST4	1.1	1.5							31.5	-	-	30	29.2	27.5	26.8	25.2	23.5	22.5	21.5	17	13				
CPm 180-ST6	CP 180-ST6																									
CPm 190-ST4	CP 190-ST4	1.5	2							37	-	-	35	34	32.2	31.5	30.2	28.7	27.8	27	22.7	18.5	15.5			
CPm 190-ST6	CP 190-ST6																									
CPm 200-ST4	CP 200-ST4	2.2	3				45	-	-	43	42	40.2	39.5	38	36.5	35.5	34.5	29.8	25.5	22	18					
CPm 200-ST6	CP 200-ST6																									

Q = Portata H = Prevalenza manometrica totale HS = Altezza di aspirazione

Tolleranza delle curve di prestazione secondo EN ISO 9906 Grado 3B.

CP 100-ST CP130-ST

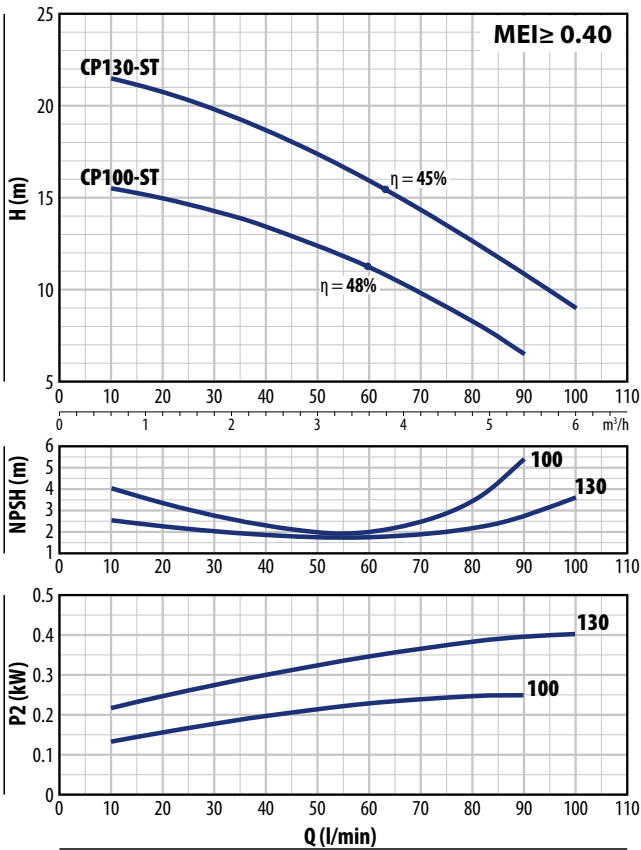

CP 132-ST

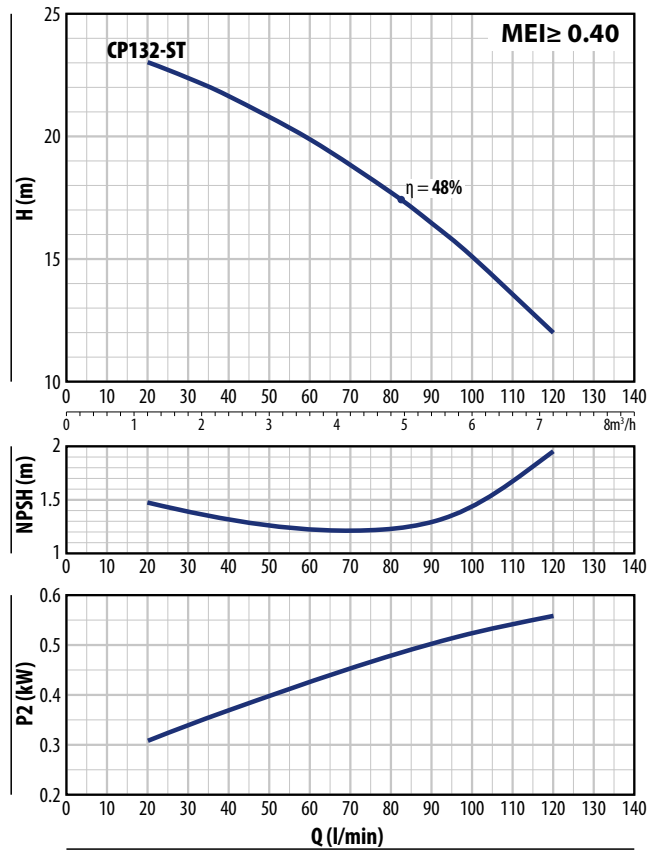

CP 150-ST

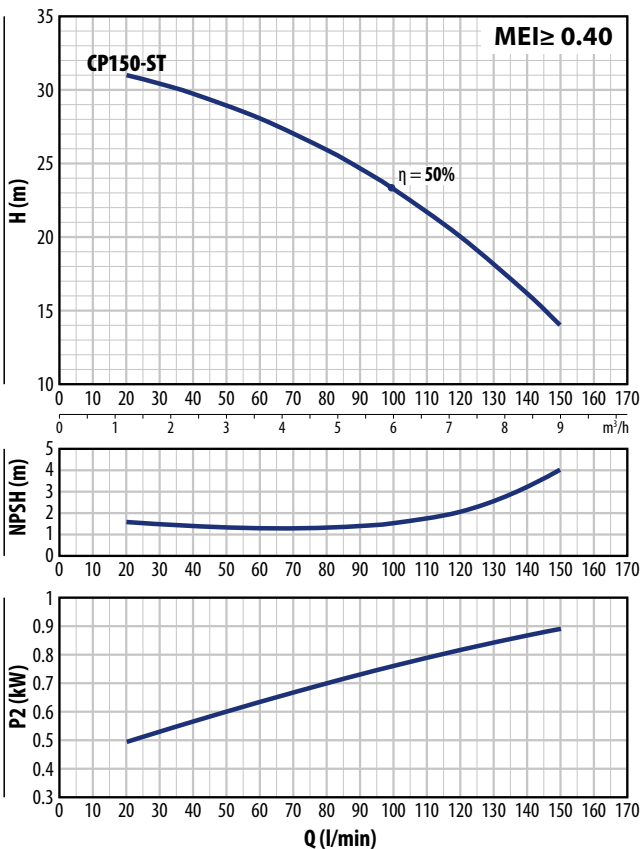

CP 158-ST

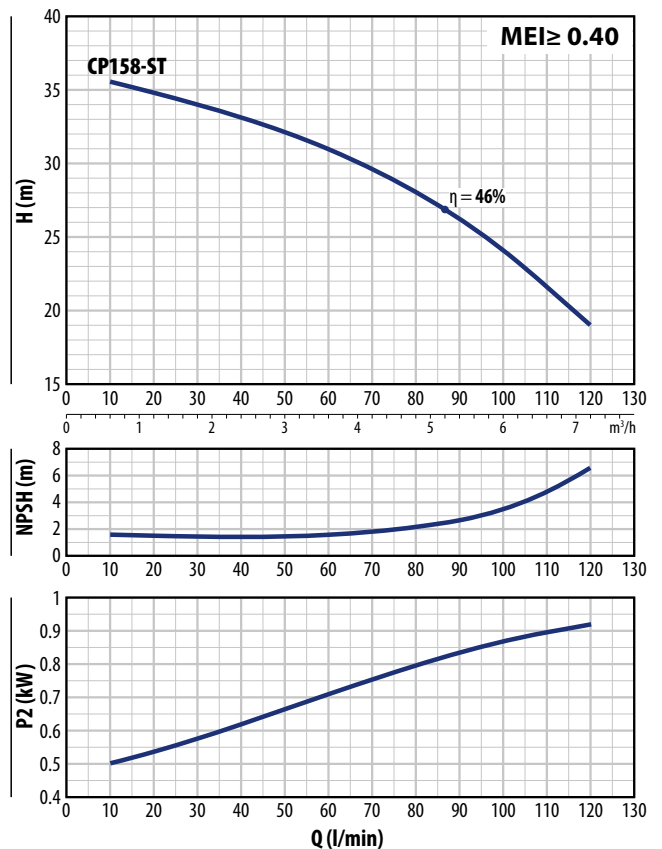

CP 170-ST

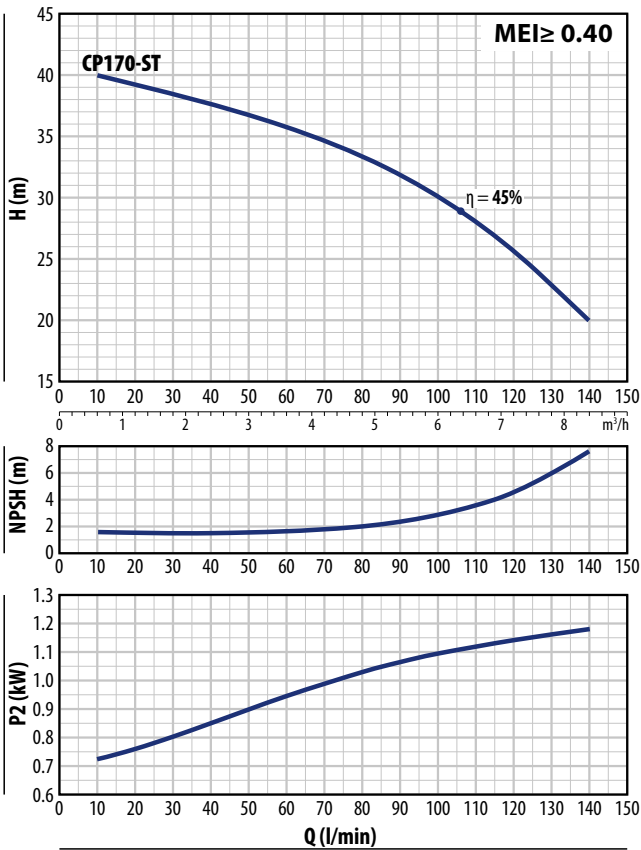

CP 170M-ST

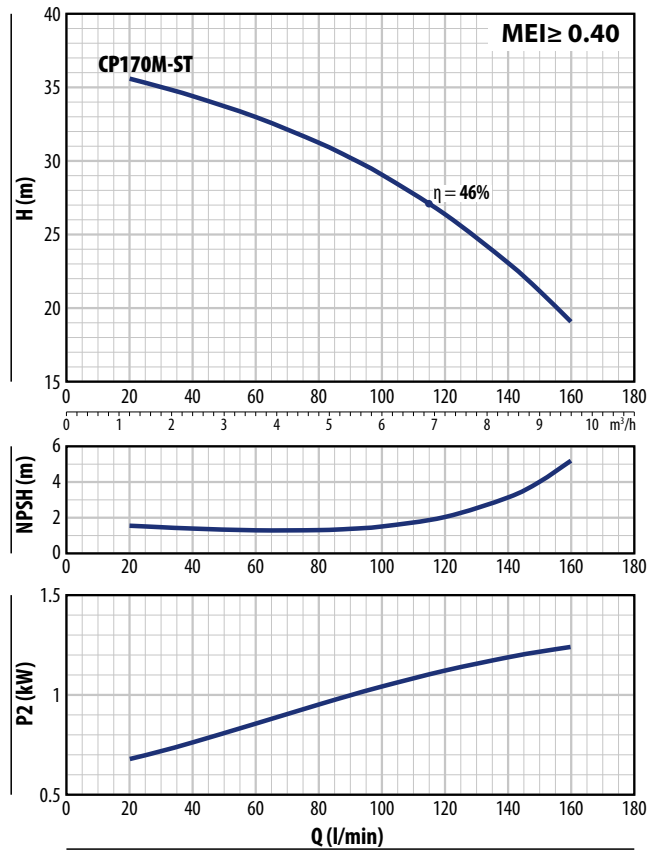

CP 180-ST CP 190-ST CP 200-ST

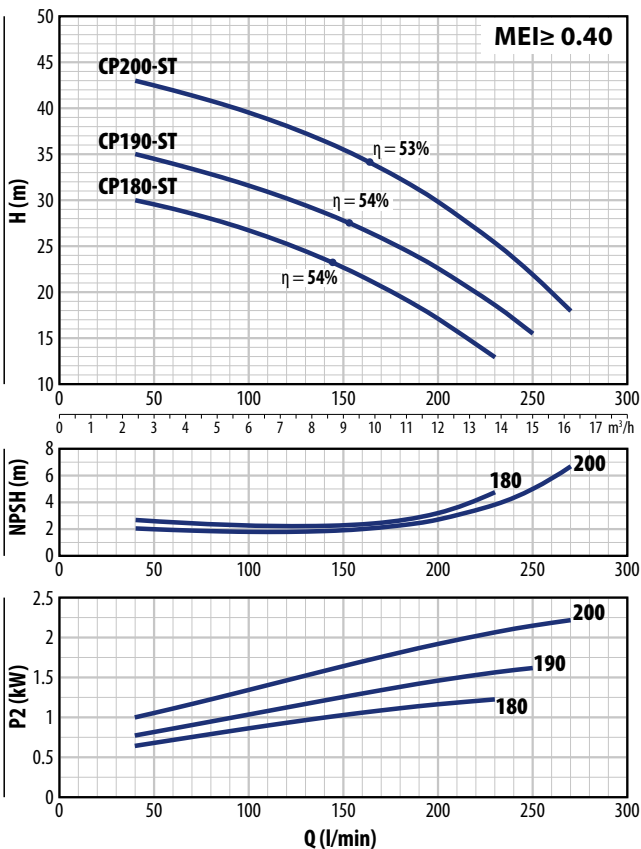

ASSORBIMENTI

TIPO	TENSIONE
Monofase	230 V
CPm 100-ST4	2.0 A
CPm 130-ST4	3.0 A
CPm 132-ST4	3.7 A
CPm 150-ST4	6.0 A
CPm 158-ST4	6.0 A
CPm 170-ST4	7.8 A
CPm 170M-ST4	7.8 A
CPm 180-ST4	8.5 A
CPm 190-ST4	10.5 A
CPm 200-ST4	12.8 A

TIPO	TENSIONE	
Trifase	230 V - Δ	400 V - 人
CP 100-ST4	1.7 A	1.0 A
CP 130-ST4	1.9 A	1.1 A
CP 132-ST4	2.2 A	1.3 A
CP 150-ST4	4.2 A	2.4 A
CP 158-ST4	4.2 A	2.4 A
CP 170-ST4	5.7 A	3.3 A
CP 170M-ST4	5.7 A	3.3 A
CP 180-ST4	5.7 A	3.3 A
CP 190-ST4	6.6 A	3.8 A
CP 200-ST4	8.8 A	5.1 A

DIMENSIONI E PESI

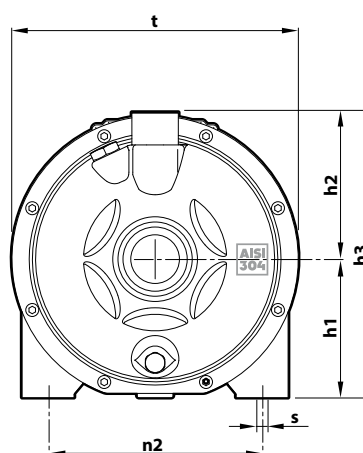
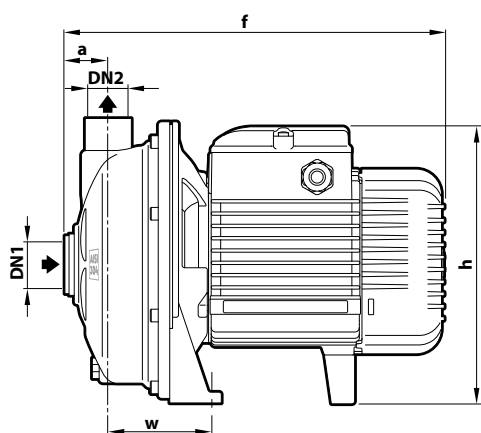

TIPO		BOCCHIE		DIMENSIONI mm										kg	
Monofase	Trifase	DN1	DN2	a	f	h	h1	h2	h3	n2	t	w	s	1~	3~
CPm 100-ST4	CP 100-ST4	1 1/4"	1"	31.5	266	181	92	93.5	185.5	120	181	68.5	9	5.8	5.8
CPm 130-ST4	CP 130-ST4													6.7	6.7
CPm 132-ST4	CP 132-ST4													7.4	7.3
CPm 150-ST4	CP 150-ST4			34	296	219 *	107	112	219	165	221	80.5	9.5	11.1	11.1
CPm 158-ST4	CP 158-ST4													11.1	11.1
CPm 170-ST4	CP 170-ST4			33.5	370	251	120	117.5	237.5	180	244	86.5	11	16.0	14.7
CPm 170M-ST4	CP 170M-ST4													15.9	14.6
CPm 180-ST4	CP 180-ST4													15.8	15.8
CPm 190-ST4	CP 190-ST4			33.5	370	250	120	117.5	237.5	180	244	86.5	11	17.1	17.1
CPm 200-ST4	CP 200-ST4													19.6	19.6
					390										

(*) h=233 mm per versioni monofase a 110 V

PALLETIZZAZIONE

TIPO		PER GROUPAGE
Monofase	Trifase	n° pompe
CPm 100-ST4	CP 100-ST4	96
CPm 130-ST4	CP 130-ST4	96
CPm 132-ST4	CP 132-ST4	96
CPm 150-ST4	CP 150-ST4	50
CPm 158-ST4	CP 158-ST4	50
CPm 170-ST4	CP 170-ST4	45
CPm 170M-ST4	CP 170M-ST4	45
CPm 180-ST4	CP 180-ST4	45
CPm 190-ST4	CP 190-ST4	45
CPm 200-ST4	CP 200-ST4	45

CARATTERISTICHE COSTRUTTIVE

1 Corpo pompa Acciaio inox **AISI 304**

2 Coperchio Acciaio inox **AISI 304**

3 Girante Acciaio inox **AISI 304**

4 Tenuta meccanica	Elettropompa	Tenuta	Albero	Materiali
	CP 100-130-131-ST4	AR-12	Ø 12 mm	Ceramica / Grafite / NBR / AISI 304
	CP 150-158-ST4	AR-14	Ø 14 mm	Ceramica / Grafite / NBR / AISI 304
	CP 170-170M-180-190-200-ST4	FN-18	Ø 18 mm	Grafite / Ceramica / NBR / AISI 316

5 Albero motore Acciaio inox **AISI 431**

6 Motore elettrico **CPm-ST4:** monofase 230 V - 50 Hz con salvamotore termico incorporato nell'avvolgimento.
CP-ST4: trifase 230/400 V - 50 Hz.
 ※ Le elettropompe sono equipaggiate con motori ad alto rendimento (IEC 60034-30-1)
 classe **IE2** per modelli monofase
 classe **IE3** per modelli trifase
 Servizio continuo **S1**

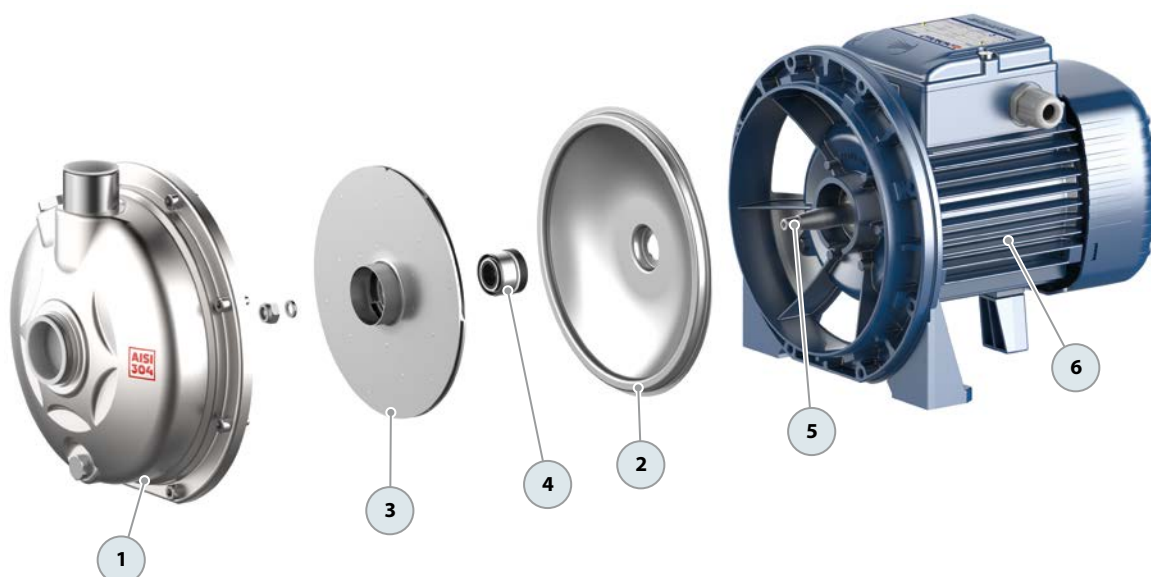

ASSORBIMENTI

TIPO	TENSIONE
Monofase	230 V
CPm 100-ST6	2.0 A
CPm 130-ST6	3.0 A
CPm 132-ST6	3.7 A
CPm 150-ST6	6.0 A
CPm 158-ST6	6.0 A
CPm 170-ST6	7.8 A
CPm 170M-ST6	7.8 A
CPm 180-ST6	8.5 A
CPm 190-ST6	10.5 A
CPm 200-ST6	12.8 A

TIPO	TENSIONE	
	230 V - Δ	400 V - Y
Trifase		
CP 100-ST6	1.7 A	1.0 A
CP 130-ST6	1.9 A	1.1 A
CP 132-ST6	2.2 A	1.3 A
CP 150-ST6	4.2 A	2.4 A
CP 158-ST6	4.2 A	2.4 A
CP 170-ST6	5.7 A	3.3 A
CP 170M-ST6	5.7 A	3.3 A
CP 180-ST6	5.7 A	3.3 A
CP 190-ST6	6.6 A	3.8 A
CP 200-ST6	8.8 A	5.1 A

DIMENSIONI E PESI

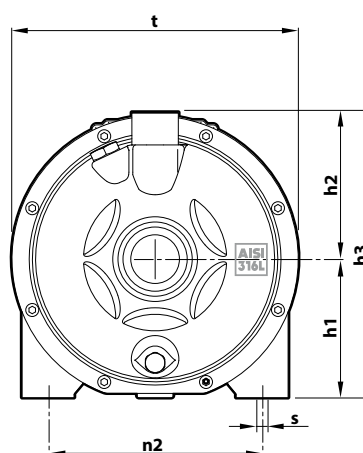
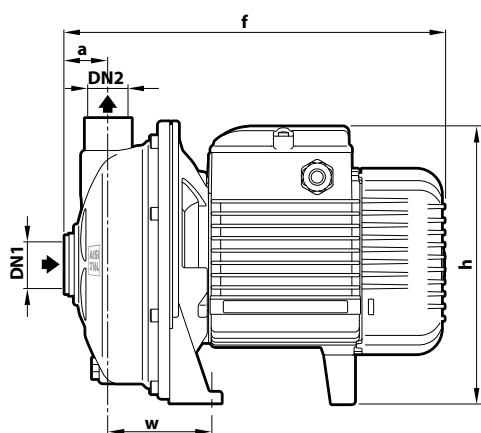

TIPO		BOCCHIE		DIMENSIONI mm										kg	
Monofase	Trifase	DN1	DN2	a	f	h	h1	h2	h3	n2	t	w	s	1~	3~
CPm 100-ST6	CP 100-ST6	1 1/4"	1"	31.5	266	181	92	93.5	185.5	120	181	68.5	9	5.8	5.8
CPm 130-ST6	CP 130-ST6													6.7	6.7
CPm 132-ST6	CP 132-ST6													7.4	7.3
CPm 150-ST6	CP 150-ST6			34	296	219 *	107	112	219	165	221	80.5	9.5	11.1	11.1
CPm 158-ST6	CP 158-ST6													11.1	11.1
CPm 170-ST6	CP 170-ST6			33.5	370	251	120	117.5	237.5	180	244	86.5	11	16.0	14.7
CPm 170M-ST6	CP 170M-ST6													15.9	14.6
CPm 180-ST6	CP 180-ST6													15.8	15.8
CPm 190-ST6	CP 190-ST6			33.5	370	250	120	117.5	237.5	180	244	86.5	11	17.1	17.1
CPm 200-ST6	CP 200-ST6													19.6	19.6
					390										

(*) h=233 mm per versioni monofase a 110 V

PALLETIZZAZIONE

TIPO		PER GROUPAGE
Monofase	Trifase	n° pompe
CPm 100-ST6	CP 100-ST6	96
CPm 130-ST6	CP 130-ST6	96
CPm 132-ST6	CP 132-ST6	96
CPm 150-ST6	CP 150-ST6	50
CPm 158-ST6	CP 158-ST6	50
CPm 170-ST6	CP 170-ST6	45
CPm 170M-ST6	CP 170M-ST6	45
CPm 180-ST6	CP 180-ST6	45
CPm 190-ST6	CP 190-ST6	45
CPm 200-ST6	CP 200-ST6	45

CARATTERISTICHE COSTRUTTIVE

1 Corpo pompa Acciaio inox **AISI 316L**

2 Coperchio Acciaio inox **AISI 316L**

3 Girante Acciaio inox **AISI 316L**

4 Tenuta meccanica	Elettropompa	Tenuta	Albero	Materiali
	CP 100-130-132-ST6	AR-12ST6	Ø 12 mm	Ceramica / Grafite / NBR / AISI 316
	CP 150-158-ST6	AR-14ST6	Ø 14 mm	Ceramica / Grafite / NBR / AISI 316
	CP 170-170M-180-190-200-ST6	FN-18ST6	Ø 18 mm	Grafite / Ceramica / NBR / AISI 316

5 Albero motore Acciaio inox **AISI 316L**

6 Motore elettrico **CPm-ST6**: monofase 230 V - 50 Hz con salvamotore termico incorporato nell'avvolgimento.
CP-ST6: trifase 230/400 V - 50 Hz.
 ※ Le elettropompe sono equipaggiate con motori ad alto rendimento (IEC 60034-30-1)
 classe **IE2** per modelli monofase
 classe **IE3** per modelli trifase
 Servizio continuo **S1**

