

-  Clean water
-  Domestic use
-  Civil use



INSTALLATION AND USE

VSP2 is a pre-assembled system intended for connecting to water mains or a primary collection tank. It provides water supply and pressurization and is ideal for residential, commercial, and public buildings. It's also suitable for hotels, park irrigation, as well as industrial water handling and treatment.

VSP2 is compatible with clean water and aqueous solutions that do not chemically or mechanically harm the materials used and are free from abrasive or fibrous substances.

PRODUCT DESCRIPTION

VSP2 is a pressurization system comprising two pumping units connected in parallel. Integrated inverter devices automatically adjust their operation to varying water demands while ensuring constant pressure.

When system pressure drops due to water withdrawal, the first **VSP** unit starts working to provide the necessary water flow rate, maintaining pressure. Once the maximum rotation speed is reached, the second **VSP** unit starts to fulfill the system's water demand.

COMPONENTS

✘ **TWO VSP PUMPING UNITS** connected in parallel via suction and discharge manifolds. Each unit is equipped with ball valves on the supply and suction side, non-return valves on the suction side (FCR, PLURIJET, MK) or on the supply side (HT-PRO). The electronics integrated in VSP can manage the alternating operation of individual units.

VSP2 is designed to protect the system from:

- ✘ dry running
- ✘ overvoltage and undervoltage
- ✘ combustion chamber
- ✘ **BASE** made of metal profile and equipped with adjustable vibration-damping feet.
- ✘ **PRESSURE TRANSDUCER** (4-20mA) installed on the supply manifold, which enables command and control of the pressurization unit.
- ✘ **CONTROL PANEL** with thermal-magnetic circuit breakers for three-phase versions and thermal-magnetic circuit breakers for single-phase versions.



VSP2 – FCR

Pressurization units comprise two multistage centrifugal pumps with an integrated inverter in the motor, capable of maintaining constant pressure in the system. They are used for water supply in residential, commercial, and public buildings, as well as for garden irrigation and general clean water movement.

TECHNICAL DATA

- Liquid temperature between **-10 °C** and **+60 °C**
- Ambient temperature between **-5 °C** and **+40 °C**
- Max. pressure in the pump body **10 bar**
- Continuous running duty **S1**



VSP2 – PLURIJET

Pressurization units comprise two self-priming multistage centrifugal pumps with an integrated inverter in the motor, capable of maintaining a constant pressure in the system. They are utilized for water supply, including from underground reservoirs, in residential, commercial, and public buildings, as well as for garden irrigation and general clean water movement.

TECHNICAL DATA

- Liquid temperature between **-10 °C** and **+40 °C**
- Ambient temperature between **-5 °C** and **+40 °C**
- Max. pressure in the pump body **10 bar**
- Continuous running duty **S1**



VSP2 – MK

Pressurization units comprise two vertical multistage pumps with an integrated inverter in the motor, capable of maintaining a constant pressure in the system. They are used for water supply in residential, commercial, and public buildings, as well as for handling clean water.

TECHNICAL DATA

- Liquid temperature between **-10 °C** and **+60 °C**
- Ambient temperature between **-5 °C** and **+40 °C**
- Max. pressure in pump body **11 bar**
- Continuous running duty **S1**



VSP2 - HT PRO

Pressurization units comprise two vertical multistage pumps with integrated inverters in the motor to maintain consistent pressure in the system. They're commonly used for water supply in commercial and public buildings, irrigation in parks and athletic fields, and for industrial water treatment.

TECHNICAL DATA

- Liquid temperature between **-10 °C** and **+60 °C**
- Ambient temperature between **-5 °C** and **+40 °C**
- Max. pressure in pump body **11 bar**
- Continuous running duty **S1**

VSP2 – FCR

FIELD AND PERFORMANCE DATA

50 Hz

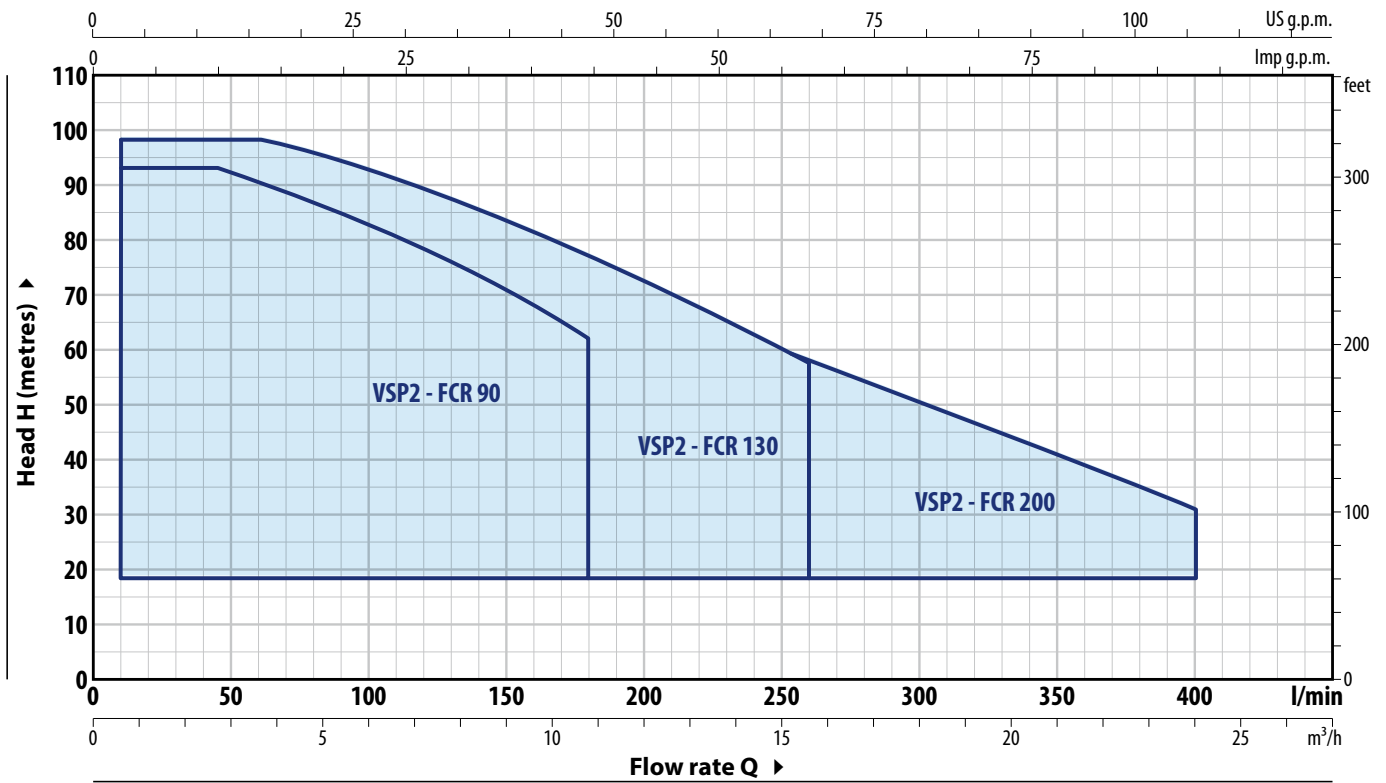

TYPE	POWER P ₂		Q	Flow rate															
	kW	HP		m ³ /h	0	0.6	1.2	2.4	4.8	6	7.2	9.6	10.8	12	14.4	15.6	18	20.4	24
Single-phase				0	10	20	40	80	100	120	160	180	200	240	260	300	340	400	
VSP2m - FCR 75/90	2x1.5	2x2	H metres	71.5	71.5	71.5	71	66	63	59.5	49.5	43.5							
VSP2m - FCR 80/130	2x1.5	2x2		74.5	74.5	74.5	74.5	69.5	66	62	52.5	48	43	34	30				
VSP2m - FCR 70/200	2x1.5	2x2		65.5	65.5	65.5	65.5	65	62.5	60	53.5	50	46	38.5	35	27.5	21	14	

TYPE	POWER P ₂		Q	Flow rate															
	kW	HP		m ³ /h	0	0.6	1.2	2.4	4.8	6	7.2	9.6	10.8	12	14.4	15.6	18	20.4	24
Three-phase				0	10	20	40	80	100	120	160	180	200	240	260	300	340	400	
VSP2 - FCR 75/90	2x1.5	2x2	H metres	71.5	71.5	71.5	71	66	63	59.5	49.5	43.5							
VSP2 - FCR 100/90	2x2.2	2x3		94	94	94	94	87.5	83	78.5	68	62.5							
VSP2 - FCR 80/130	2x1.5	2x2		74.5	74.5	74.5	74.5	69.5	66	62	52.5	48	43	34	30				
VSP2 - FCR 105/130	2x2.2	2x3		98	98	98	98	96	93	89.5	81	76.5	72	62	57.5				
VSP2 - FCR 70/200	2x1.5	2x2		65.5	65.5	65.5	65.5	65	62.5	60	53.5	50	46	38.5	35	27.5	21	14	
VSP2 - FCR 95/200	2x2.2	2x3		87.5	87.5	87.5	87.5	87	85	82.5	76.5	73.5	70	62.5	58.5	50.5	42	31	

Q = Flow rate H = Total manometric head

Performance curves comply with EN ISO 9906 Grade 3B tolerance limits.

✘ The data shown in the diagram and tables indicate performance with 2 pumps in operation

PERFORMANCE CURVES

50 Hz

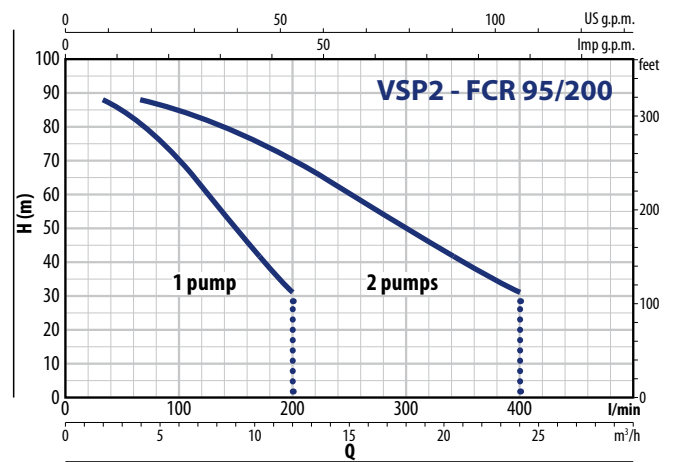
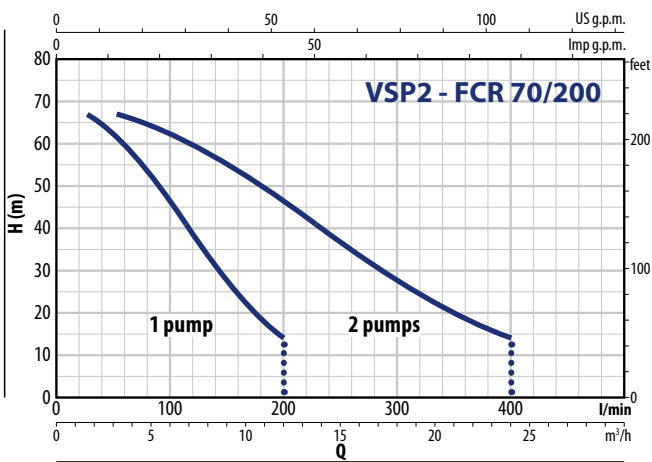
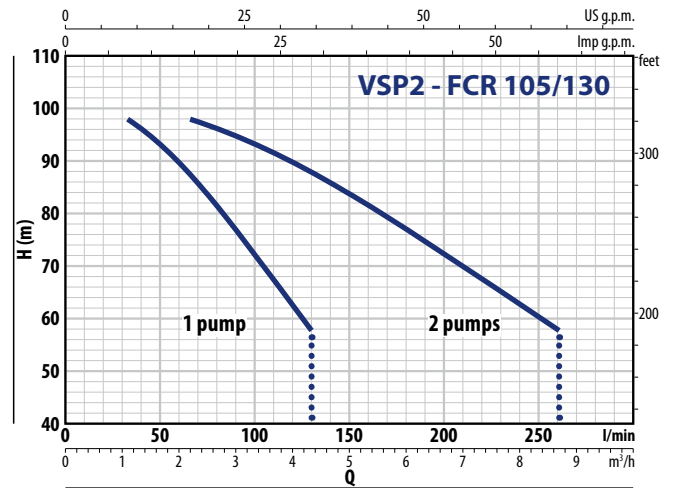
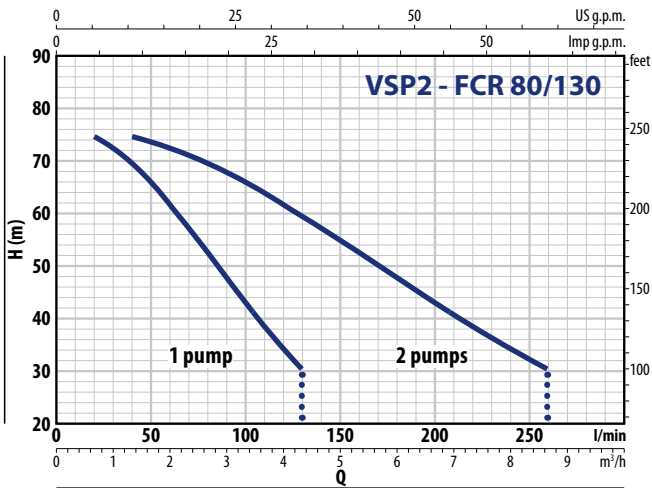
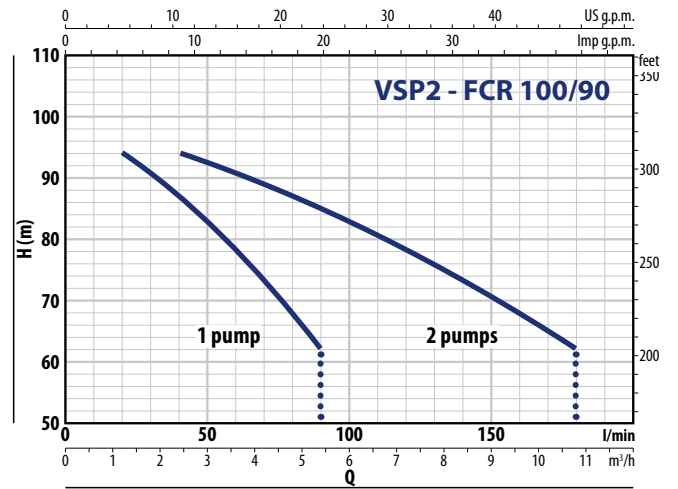
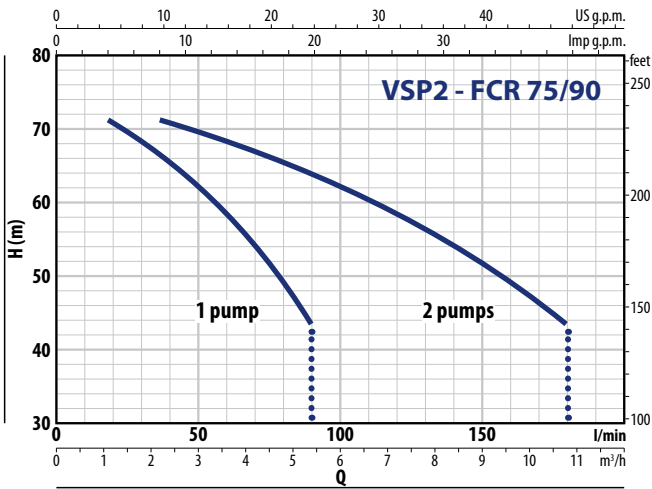

VSP2 - FCR

ABSORPTION

TYPE	VOLTAGE
Single-phase	230 V
VSP2m - FCR 75/90	2 x 9.8 A
VSP2m - FCR 80/130	2 x 9.8 A
VSP2m - FCR 70/200	2 x 9.8 A

TYPE	VOLTAGE
Three-phase	400 V
VSP2 - FCR 75/90	2 x 3.6 A
VSP2 - FCR 100/90	2 x 4.9 A
VSP2 - FCR 80/130	2 x 3.6 A
VSP2 - FCR 105/130	2 x 4.9 A
VSP2 - FCR 70/200	2 x 3.6 A
VSP2 - FCR 95/200	2 x 4.9 A

DIMENSIONS AND WEIGHT

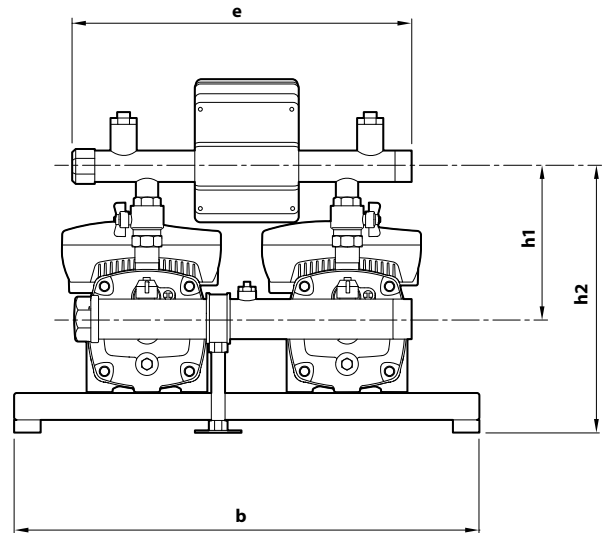
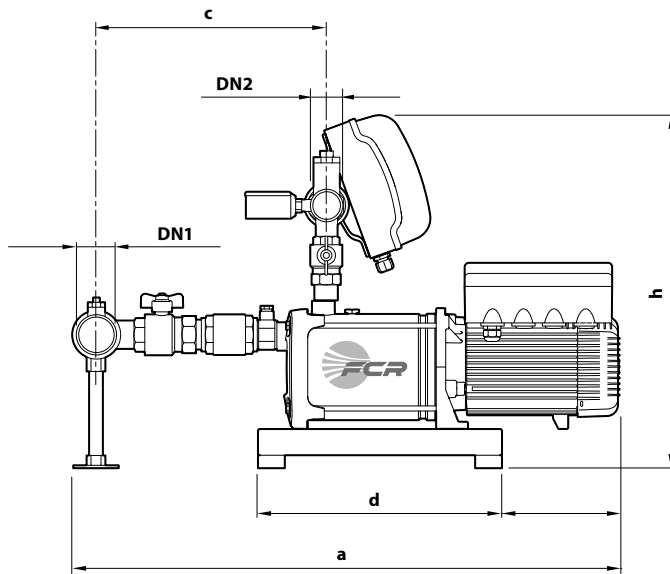

TYPE		PORTS		DIMENSIONS mm								kg	
Single-phase	Three-phase	DN1	DN2	a	b	c	d	e	h	h1	h2	1~	3~
VSP2m - FCR 75/90	VSP2 - FCR 75/90	2"	1½"	760	700	339	370	510	560	205	394	80	80
-	VSP2 - FCR 100/90			786								-	81
VSP2m - FCR 80/130	VSP2 - FCR 80/130			760								81	81
-	VSP2 - FCR 105/130			786								-	81
VSP2m - FCR 70/200	VSP2 - FCR 70/200	2½"	1½"	803	375							87	87
-	VSP2 - FCR 95/200			829								-	87

FIELD AND PERFORMANCE DATA

50 Hz

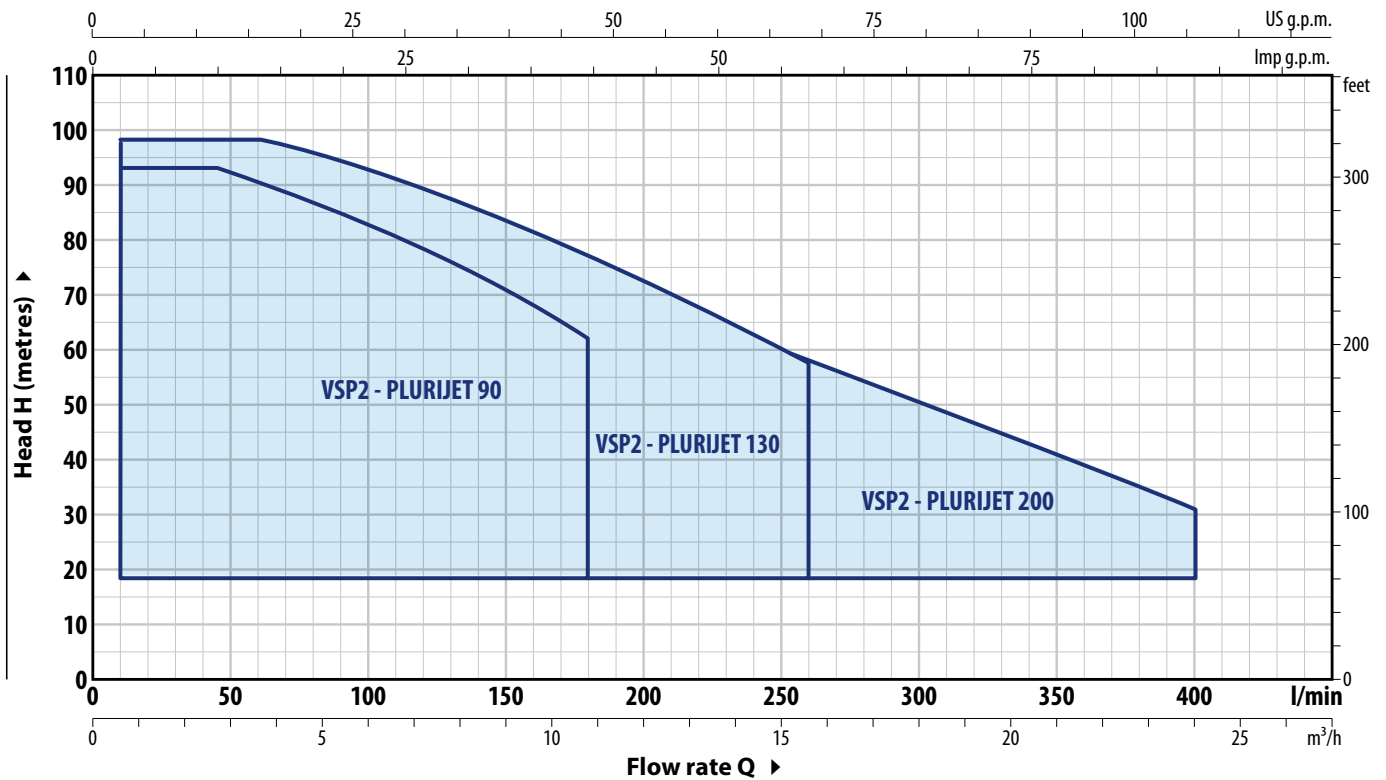

TYPE	POWER P ₂		Q	Flow rate															
	kW	HP		m ³ /h	0	0.6	1.2	2.4	4.8	6	7.2	9.6	10.8	12	14.4	15.6	18	20.4	24
Single-phase				0	10	20	40	80	100	120	160	180	200	240	260	300	340	400	
VSP2m - PLURIJET 75/90	2x1.5	2x2	H metres	71.5	71.5	71.5	71	66	63	59.5	49.5	43.5							
VSP2m - PLURIJET 80/130	2x1.5	2x2		74.5	74.5	74.5	74.5	69.5	66	62	52.5	48	43	34	30				
VSP2m - PLURIJET 70/200	2x1.5	2x2		65.5	65.5	65.5	65.5	65	62.5	60	53.5	50	46	38.5	35	27.5	21	14	

TYPE	POWER P ₂		Q	Flow rate															
	kW	HP		m ³ /h	0	0.6	1.2	2.4	4.8	6	7.2	9.6	10.8	12	14.4	15.6	18	20.4	24
Three-phase				0	10	20	40	80	100	120	160	180	200	240	260	300	340	400	
VSP2 - PLURIJET 75/90	2x1.5	2x2	H metres	71.5	71.5	71.5	71	66	63	59.5	49.5	43.5							
VSP2 - PLURIJET 100/90	2x2.2	2x3		94	94	94	94	87.5	83	78.5	68	62.5							
VSP2 - PLURIJET 80/130	2x1.5	2x2		74.5	74.5	74.5	74.5	69.5	66	62	52.5	48	43	34	30				
VSP2 - PLURIJET 105/130	2x2.2	2x3		98	98	98	98	96	93	89.5	81	76.5	72	62	57.5				
VSP2 - PLURIJET 70/200	2x1.5	2x2		65.5	65.5	65.5	65.5	65	62.5	60	53.5	50	46	38.5	35	27.5	21	14	
VSP2 - PLURIJET 95/200	2x2.2	2x3		87.5	87.5	87.5	87.5	87	85	82.5	76.5	73.5	70	62.5	58.5	50.5	42	31	

Q = Flow rate H = Total manometric head

Performance curves comply with EN ISO 9906 Grade 3B tolerance limits.

✳ The data shown in the diagram and tables indicate performance with 2 pumps in operation

VSP2 - PLURIJET

PERFORMANCE CURVES

50 Hz

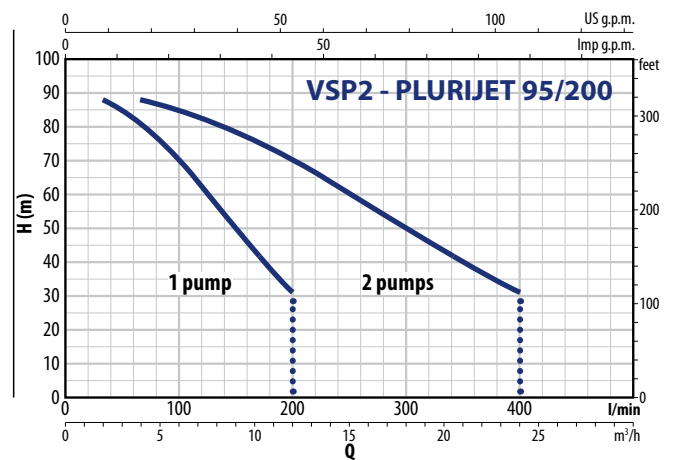
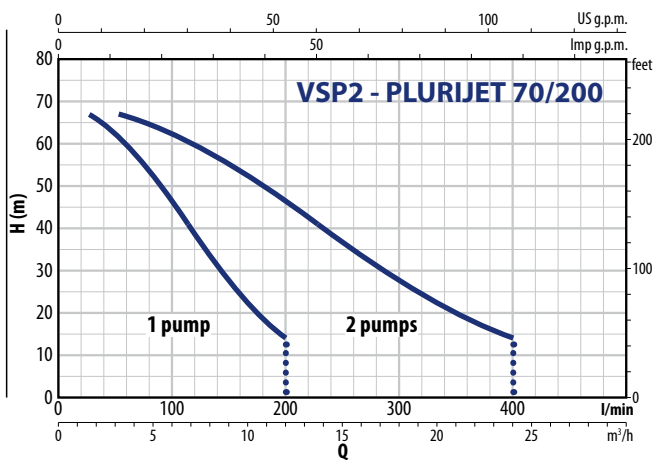
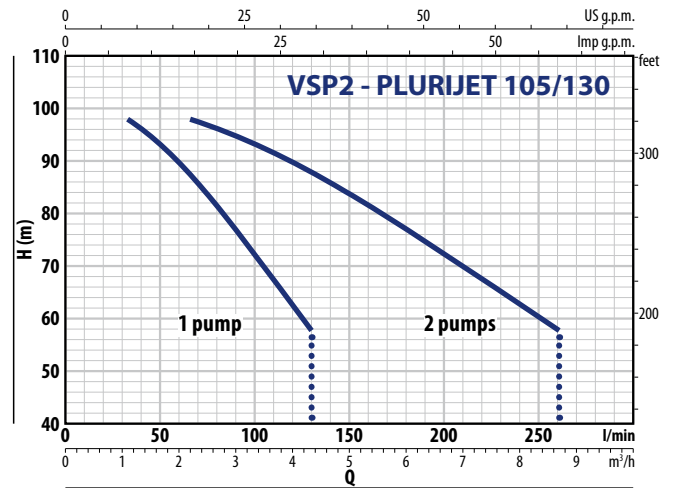
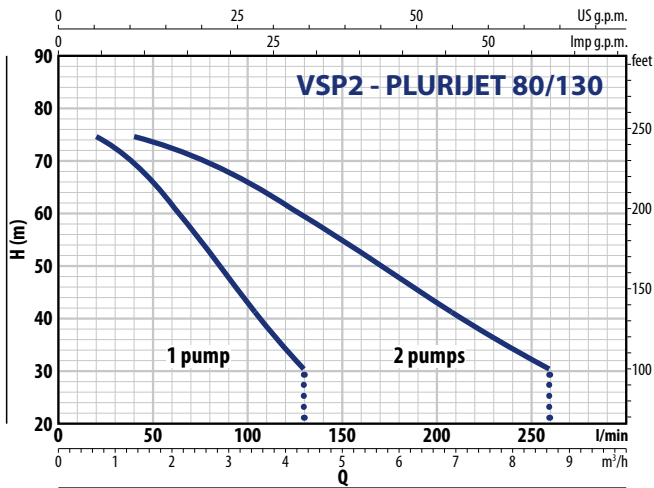
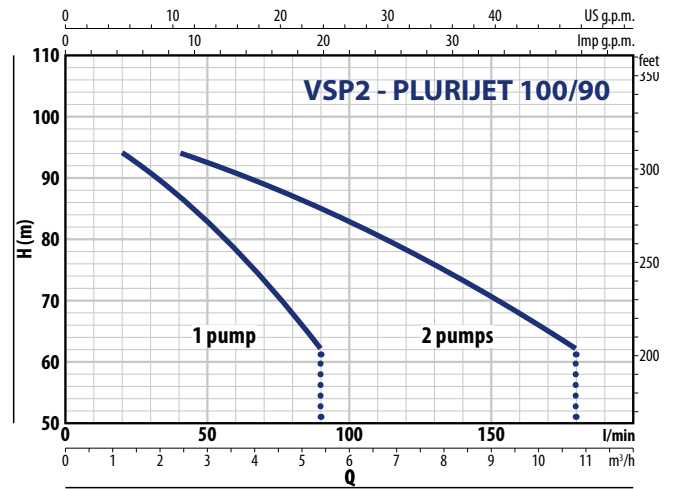
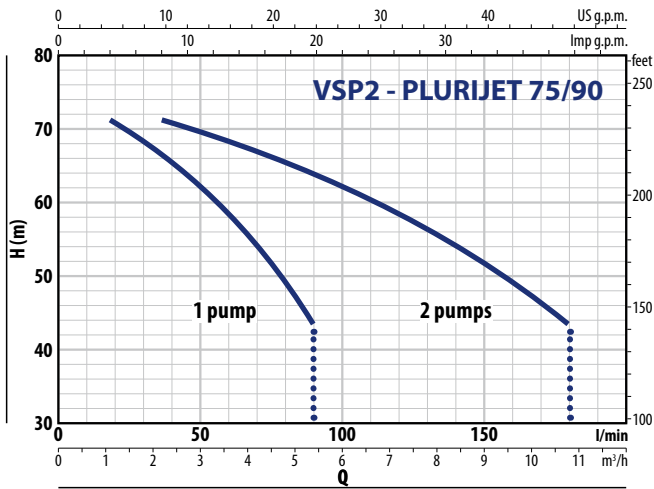

ABSORPTION

TYPE	VOLTAGE
Single-phase	230 V
VSP2m - PLURIJET 75/90	2 x 9.8 A
VSP2m - PLURIJET 80/130	2 x 9.8 A
VSP2m - PLURIJET 70/200	2 x 9.8 A

TYPE	VOLTAGE
Three-phase	400 V
VSP2 - PLURIJET 75/90	2 x 3.6 A
VSP2 - PLURIJET 100/90	2 x 4.9 A
VSP2 - PLURIJET 80/130	2 x 3.6 A
VSP2 - PLURIJET 105/130	2 x 4.9 A
VSP2 - PLURIJET 70/200	2 x 3.6 A
VSP2 - PLURIJET 95/200	2 x 4.9 A

DIMENSIONS AND WEIGHT

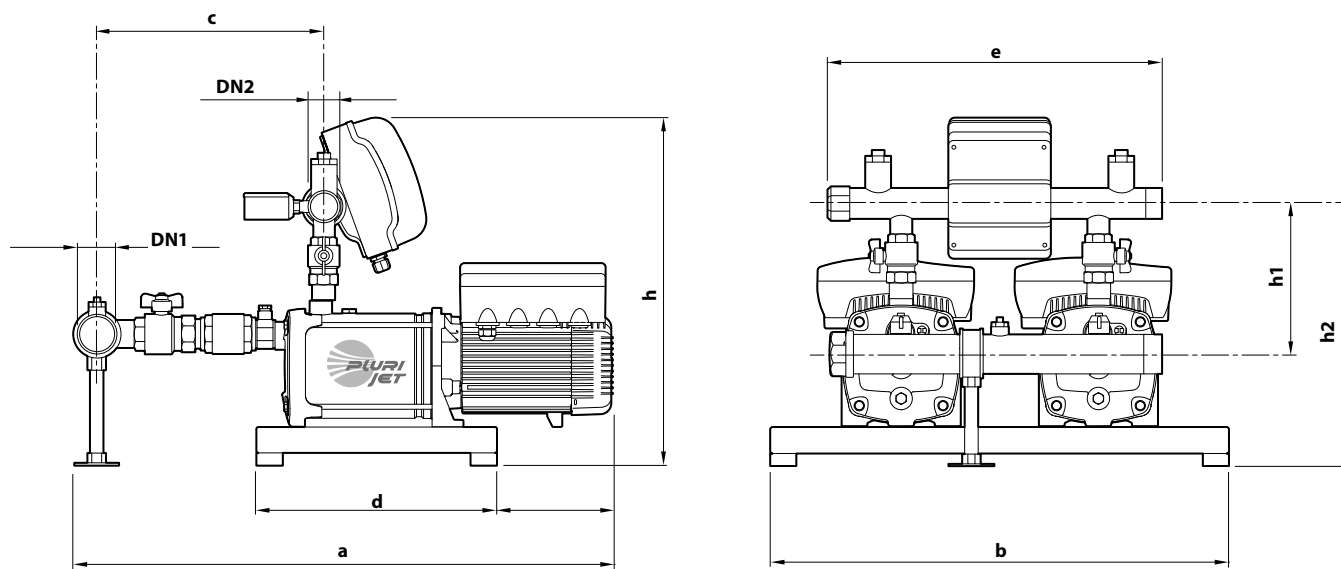

TYPE	PORTS	DIMENSIONS mm										kg		
		DN1	DN2	a	b	c	d	e	h	h1	h2	1~	3~	
Single-phase	Three-phase													
VSP2m - PLURIJET 75/90	VSP2 - PLURIJET 75/90	2"	1½"	812	700	339	370	510	560	205	394	80	80	
-	VSP2 - PLURIJET 100/90			838								-	85	
VSP2m - PLURIJET 80/130	VSP2 - PLURIJET 80/130			812								80	81	
-	VSP2 - PLURIJET 105/130			838								-	85	
VSP2m - PLURIJET 70/200	VSP2 - PLURIJET 70/200	2½"	1½"	855	375							83	83	
-	VSP2 - PLURIJET 95/200			881								-	87	

VSP2 - MK

FIELD AND PERFORMANCE DATA

50 Hz

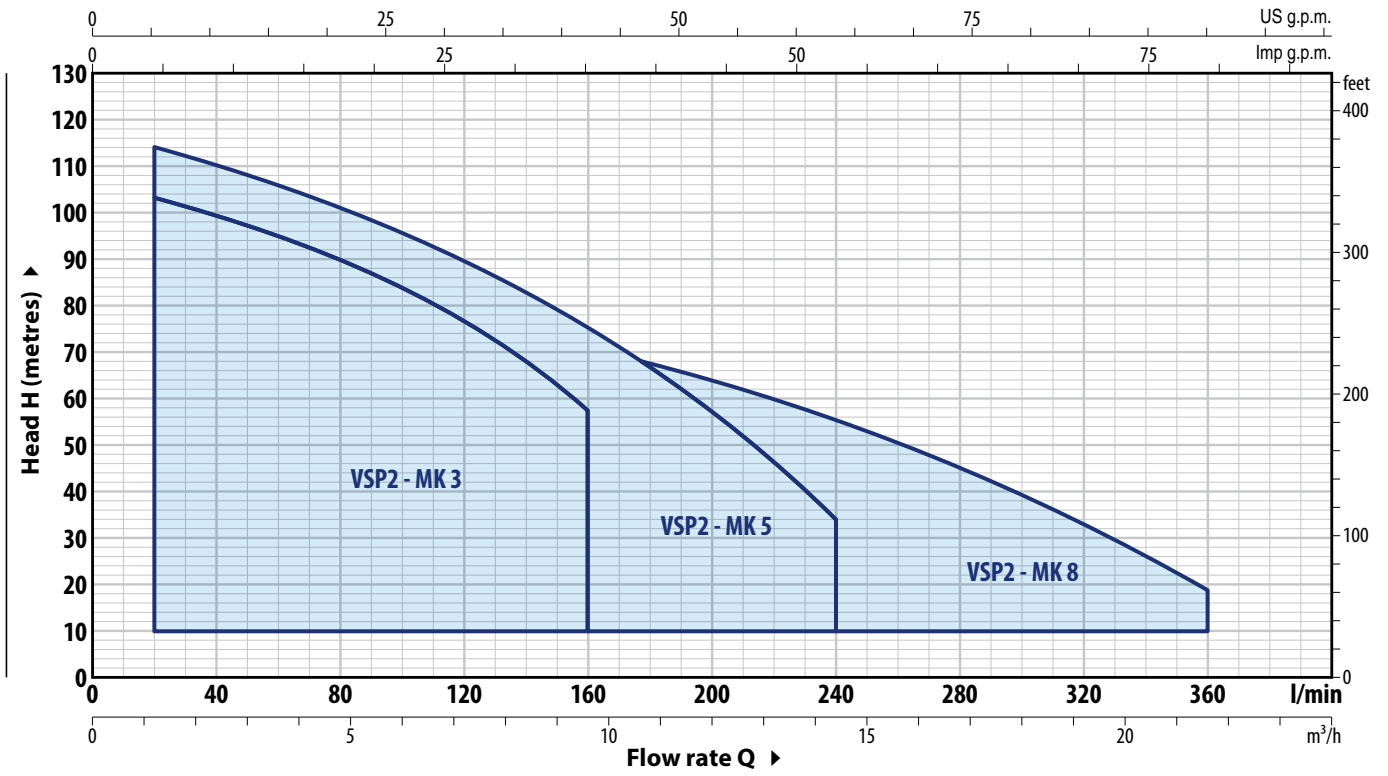

TYPE		POWER P ₂		Q m ³ /h l/min	H												
Single-phase	Three-phase	kW	HP		metres	0	1.2	2.4	4.8	7.2	9.6	12.0	14.4	16.8	19.2	21.6	
					0	20	40	80	120	160	200	240	280	320	360		
VSP2m - MK 3/3	VSP2 - MK 3/3	2x0.75	2x1	H metres	52.5	51.5	50	45	38.5	29							
VSP2m - MK 3/5	VSP2 - MK 3/5	2x1.1	2x1.5		87	85	83	75	64	48							
VSP2m - MK 3/6	VSP2 - MK 3/6	2x1.5	2x2		105	103	100	90	77	58							
VSP2m - MK 5/4	VSP2 - MK 5/4	2x0.75	2x1		57	-	54	50	45	37.5	28.5	17					
VSP2m - MK 5/5	VSP2 - MK 5/5	2x1.1	2x1.5		71	-	67.5	62.5	56	47	35.5	21.5					
VSP2m - MK 5/7	VSP2 - MK 5/7	2x1.5	2x2		99	-	95	88	78	66	50	30					
-	VSP2 - MK 5/8	2x2.2	2x3		114	-	108	100	90	75	57	34					
VSP2m - MK 8/4	VSP2 - MK 8/4	2x1.1	2x1.5		56	-	-	53.5	51	47.5	43	37.5	30.5	22.1	12		
VSP2m - MK 8/5	VSP2 - MK 8/5	2x1.5	2x2		70	-	-	67	64	59.5	54	47	38	27.5	15.5		
-	VSP2 - MK 8/6	2x2.2	2x3		84	-	-	80	77	72	64.5	56	45.5	33	18.5		

Q = Flow rate H = Total manometric head

Performance curves comply with EN ISO 9906 Grade 3B tolerance limits.

✘ The data shown in the diagram and table indicate performance with 2 pumps in operation

PERFORMANCE CURVES

50 Hz

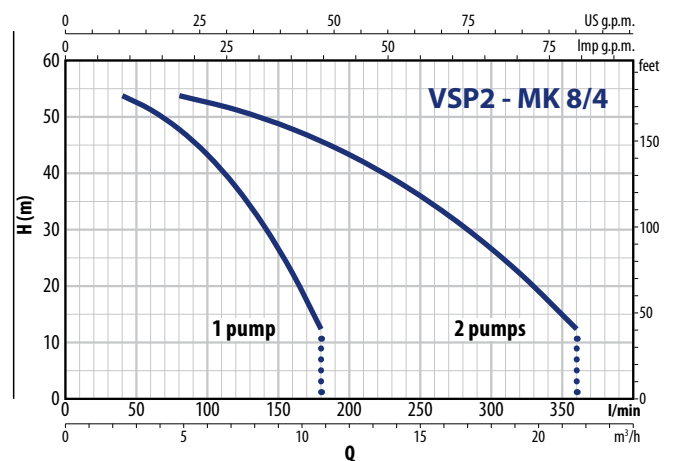
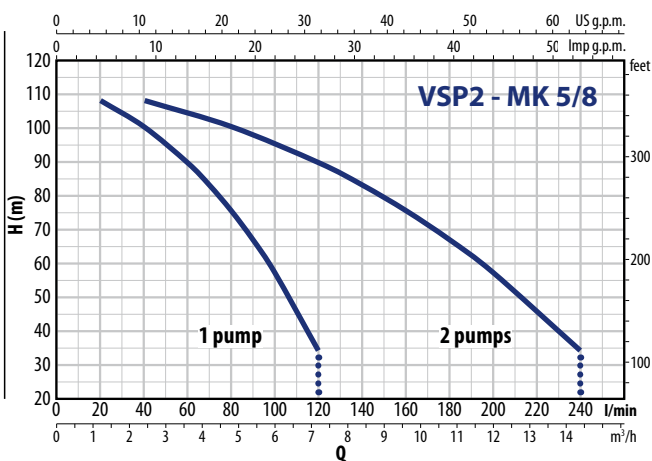
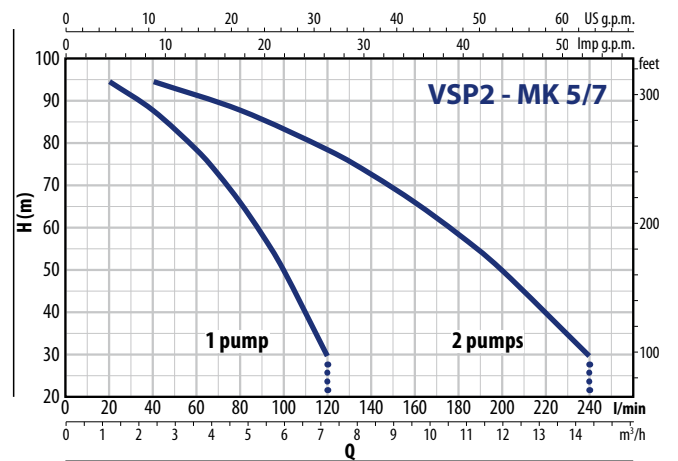
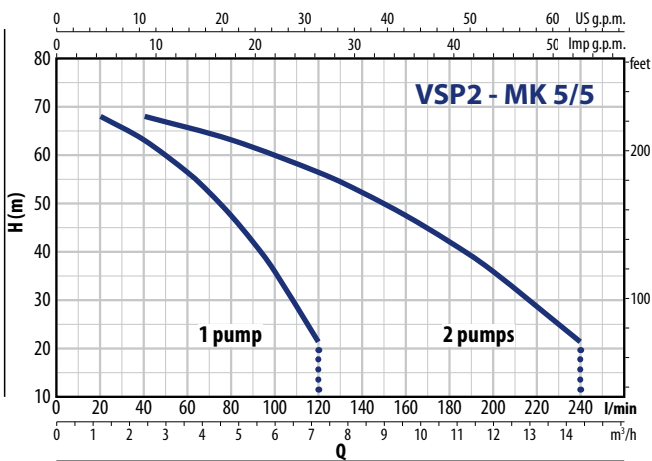
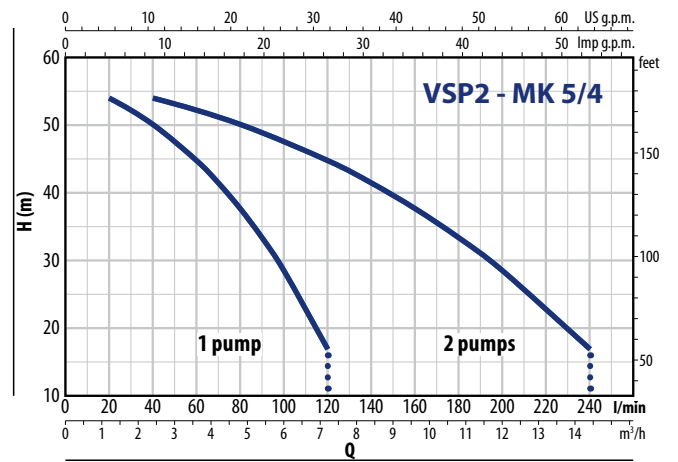
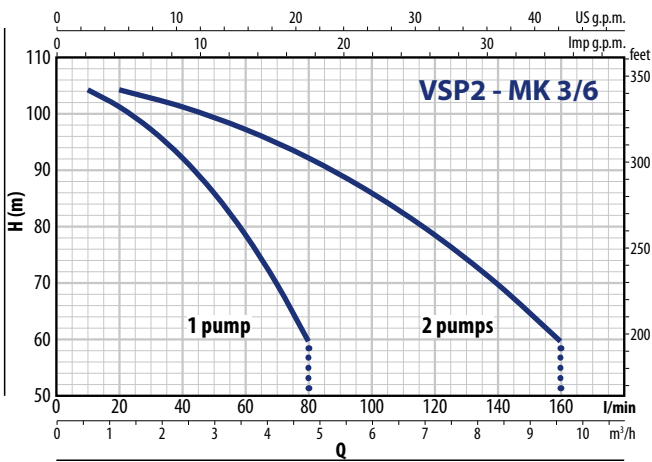
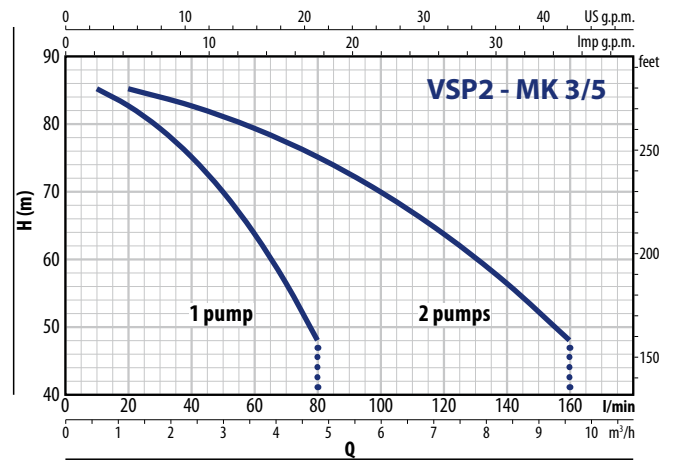
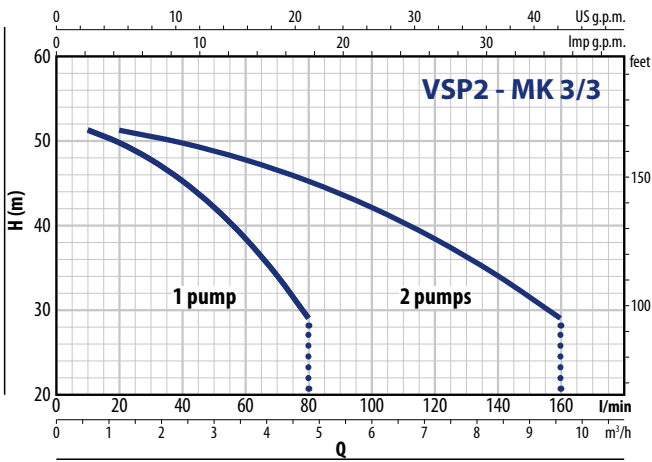

VSP2 - MK

PERFORMANCE CURVES

50 Hz

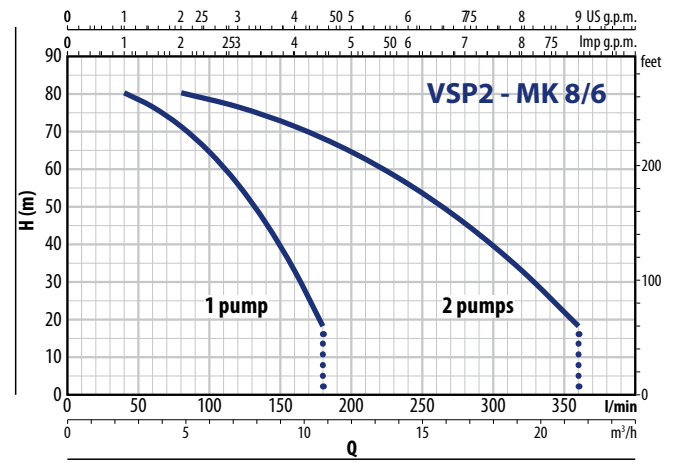
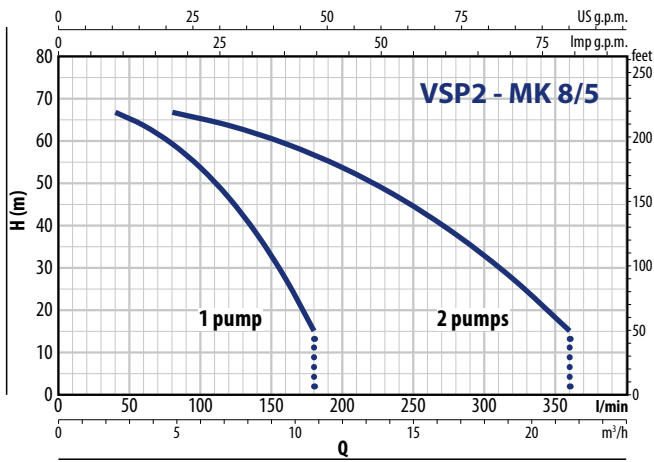

ABSORPTION

TYPE	VOLTAGE
Single-phase	230 V
VSP2m - MK 3/3	2 x 6.2 A
VSP2m - MK 3/5	2 x 7.8 A
VSP2m - MK 3/6	2 x 9.0 A
VSP2m - MK 5/4	2 x 6.4 A
VSP2m - MK 5/5	2 x 6.5 A
VSP2m - MK 5/7	2 x 9.0 A
VSP2m - MK 8/4	2 x 8.3 A
VSP2m - MK 8/5	2 x 10.0 A

TYPE	VOLTAGE
Three-phase	400 V
VSP2 - MK 3/3	2 x 1.7 A
VSP2 - MK 3/5	2 x 2.3 A
VSP2 - MK 3/6	2 x 2.8 A
VSP2 - MK 5/4	2 x 2.0 A
VSP2 - MK 5/5	2 x 2.2 A
VSP2 - MK 5/7	2 x 3.0 A
VSP2 - MK 5/8	2 x 3.5 A
VSP2 - MK 8/4	2 x 2.8 A
VSP2 - MK 8/5	2 x 3.4 A
VSP2 - MK 8/6	2 x 3.8 A

DIMENSIONS AND WEIGHT

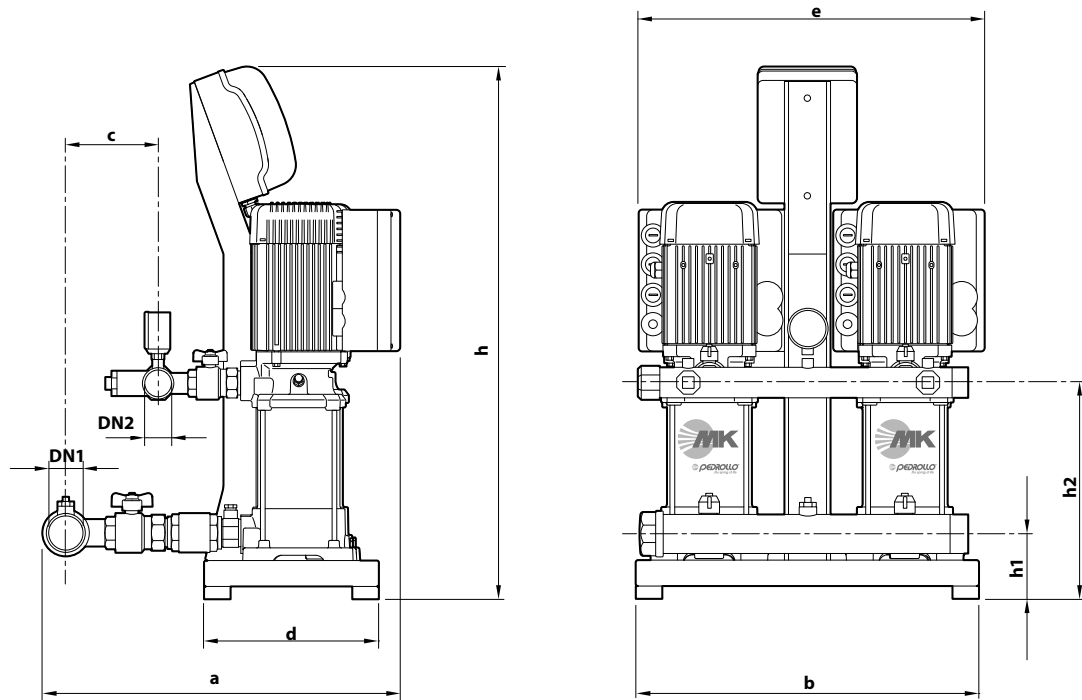

TYPE		PORTS		DIMENSIONS mm							kg		
Single-phase	Three-phase	DN1	DN2	a	b	c	d	e	h	h1	h2	1~	3~
VSP2m - MK 3/3	VSP2 - MK 3/3	2"	1½"	555	530	135	270	510	863	102	235	75	75
VSP2m - MK 3/5	VSP2 - MK 3/5										289	79	79
VSP2m - MK 3/6	VSP2 - MK 3/6										316	83	83
VSP2m - MK 5/4	VSP2 - MK 5/4										262	76	76
VSP2m - MK 5/5	VSP2 - MK 5/5										289	79	79
VSP2m - MK 5/7	VSP2 - MK 5/7										343	83	83
-	VSP2 - MK 5/8										370	-	84
VSP2m - MK 8/4	VSP2 - MK 8/4	2½"	1½"	600	171						316	82	82
VSP2m - MK 8/5	VSP2 - MK 8/5										262	83	83
-	VSP2 - MK 8/6										289	-	89

VSP2 - HT-PRO

FIELD AND PERFORMANCE DATA

50 Hz

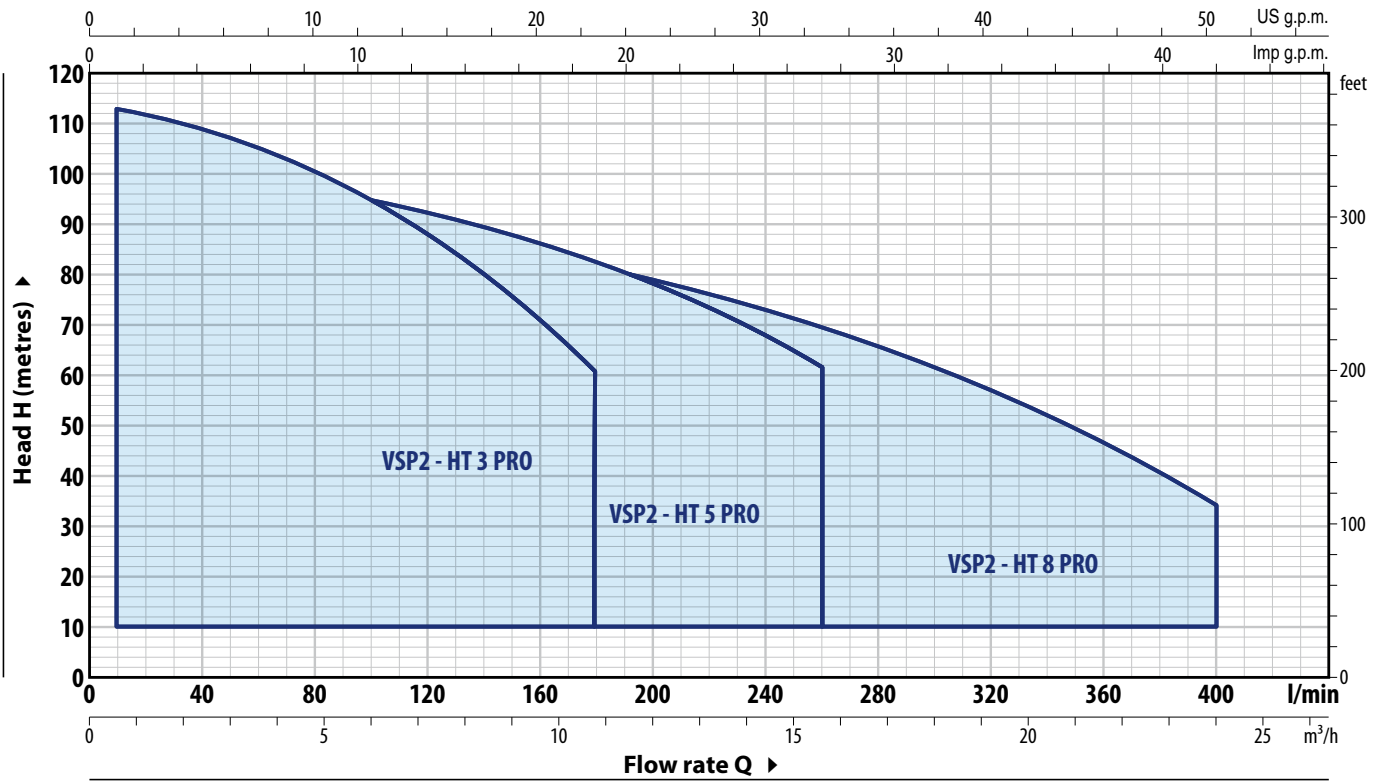

TYPE		POWER (P ₂)		Q	Flow rate								
Single-phase	Three-phase	kW	HP		m ³ /h	0	0.6	1.2	2.4	4.8	7.2	9.6	10.8
				l/min	0	10	20	40	80	120	160	180	
VSP2 - HTm 3/4 PRO	VSP2 - HT 3/4 PRO	2x0.75	2x1	H metres	65	65	63.5	62	57	50	40.5	35	
VSP2 - HTm 3/5 PRO	VSP2 - HT 3/5 PRO	2x1.1	2x1.5		81	80	79	77	71	62.5	51	44	
VSP2 - HTm 3/6 PRO	VSP2 - HT 3/6 PRO	2x1.5	2x2		97	96	95	93	86	75	61	52	
-	VSP2 - HT 3/7 PRO	2x1.8	2x2.5		113	112	111	108	100	88	71	61	

TYPE		POWER (P ₂)		Q	Flow rate										
Single-phase	Three-phase	kW	HP		m ³ /h	0	0.6	1.2	2.4	4.8	7.2	9.6	10.8	12	15.6
				l/min	0	10	20	40	80	120	160	180	200	260	
VSP2 - HTm 5/2 PRO	VSP2 - HT 5/2 PRO	2x0.75	2x1	H metres	35	35	32.7	32.3	32.5	31	25.5	27.5	26	16	
VSP2 - HTm 5/3 PRO	VSP2 - HT 5/3 PRO	2x1.1	2x1.5		51.5	52	51	50.5	49	46.5	43	41	39	31	
VSP2 - HTm 5/4 PRO	VSP2 - HT 5/4 PRO	2x1.5	2x2		68.5	68.5	68	67	65	62	57.5	55	52	41	
-	VSP2 - HT 5/5 PRO	2x1.8	2x2.5		86	85	85	84	81	77	72	68.5	65	51.5	
-	VSP2 - HT 5/6 PRO	2x2.2	2x3		103	103	102	101	98	93	86	82	78	62	

TYPE		POWER (P ₂)		Q	Flow rate											
Single-phase	Three-phase	kW	HP		m ³ /h	0	2.4	4.8	7.2	9.6	12	14.4	16.8	19.2	21.6	24
				l/min	0	40	80	120	160	200	240	280	320	360	400	
VSP2 - HTm 8/3 PRO	VSP2 - HT 8/3 PRO	2x1.1	2x1.5	H metres	47	46.5	45.5	44	42	39.5	36.5	32.5	28	23.1	17	
VSP2 - HTm 8/4 PRO	VSP2 - HT 8/4 PRO	2x1.5	2x2		62.5	62	60.5	58.5	56	53	48.5	43.5	37.5	31	23	
-	VSP2 - HT 8/5 PRO	2x1.8	2x2.5		78	77.5	76	73	70	66	61	54.5	47	38.5	28.5	
-	VSP2 - HT 8/6 PRO	2x2.2	2x3		94	93	91	88	84	79	73	65.5	56.5	46	34.5	

Q = Flow rate H = Total manometric head

Performance curves comply with EN ISO 9906 Grade 3B tolerance limits.

✘ The data shown in the diagram and tables indicate performance with 2 pumps in operation

PERFORMANCE CURVES

50 Hz

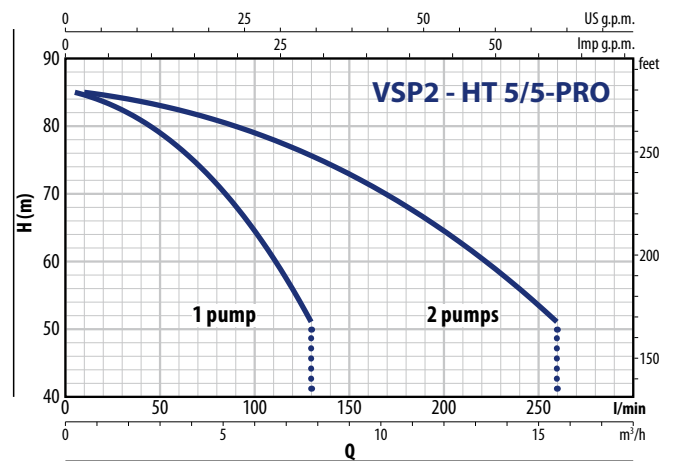
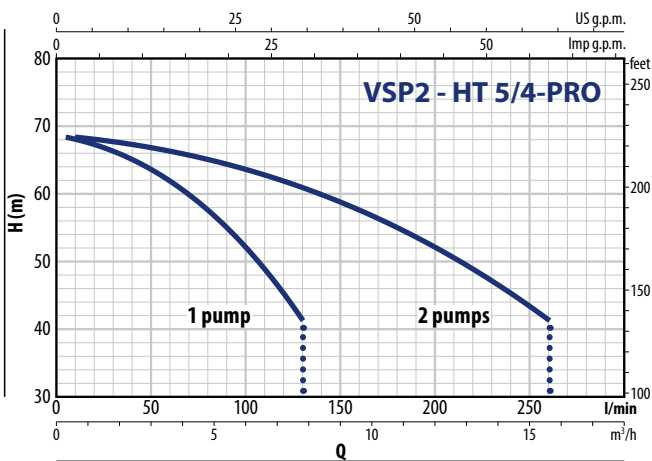
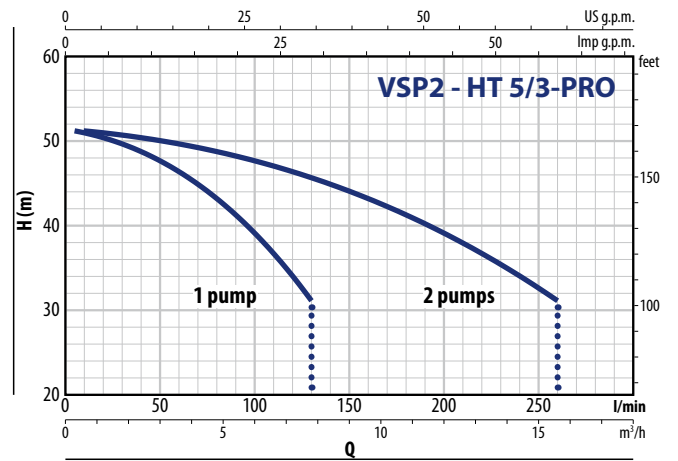
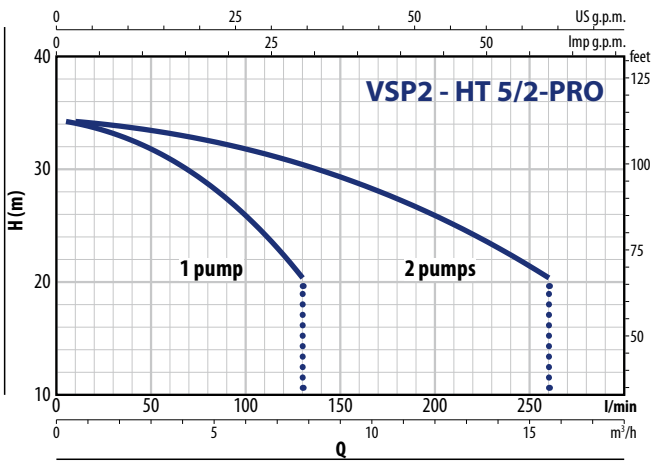
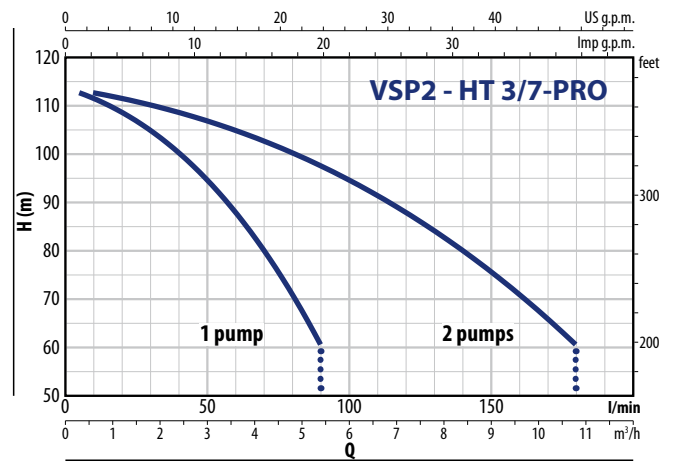
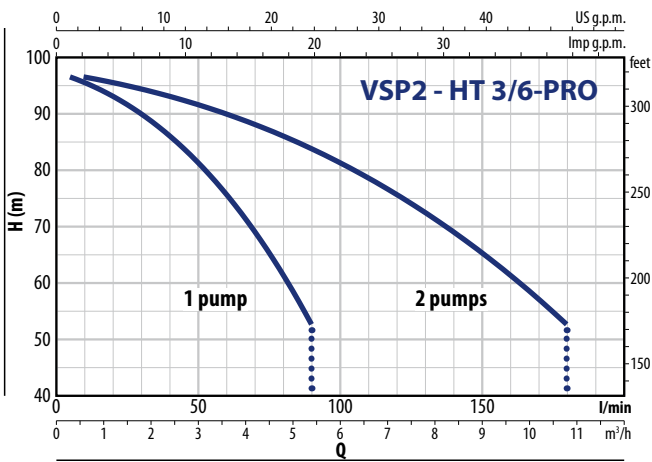
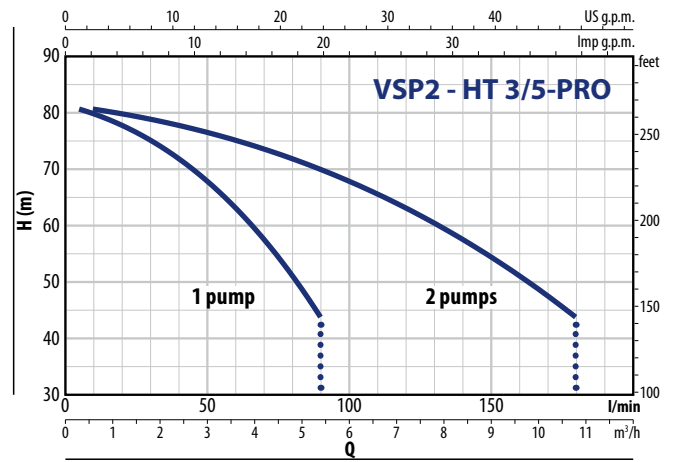
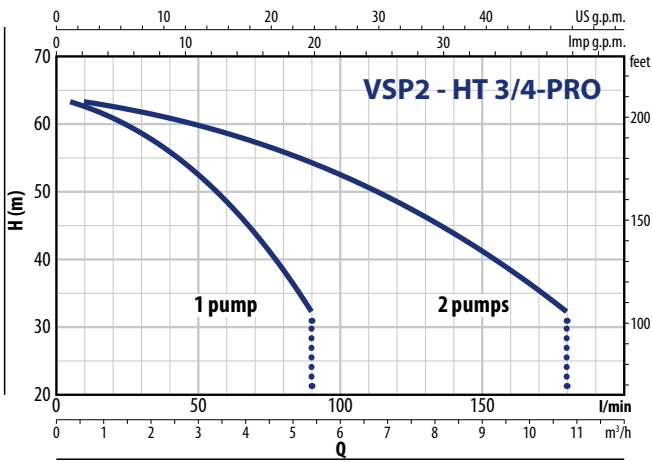

VSP2 - HT-PRO

PERFORMANCE CURVES

50 Hz

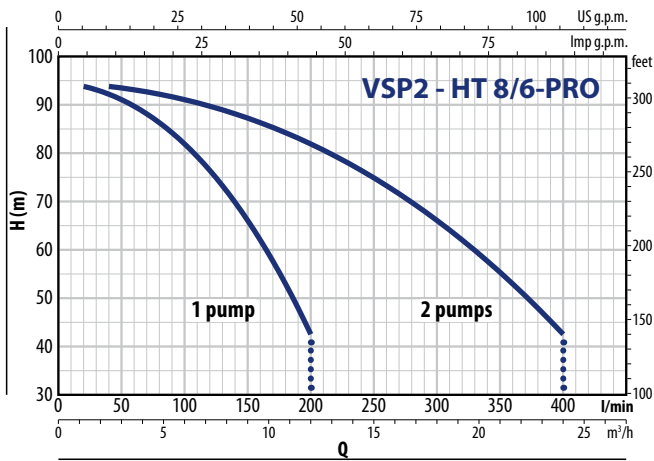
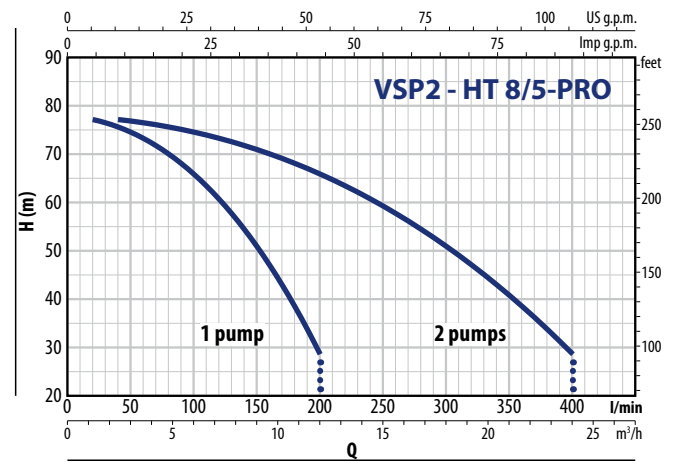
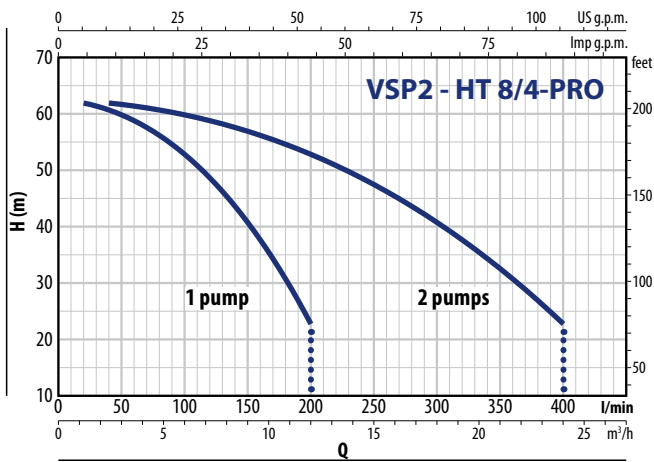
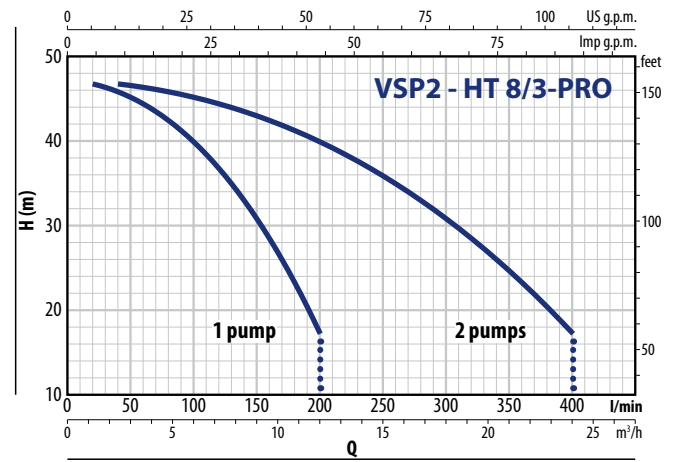
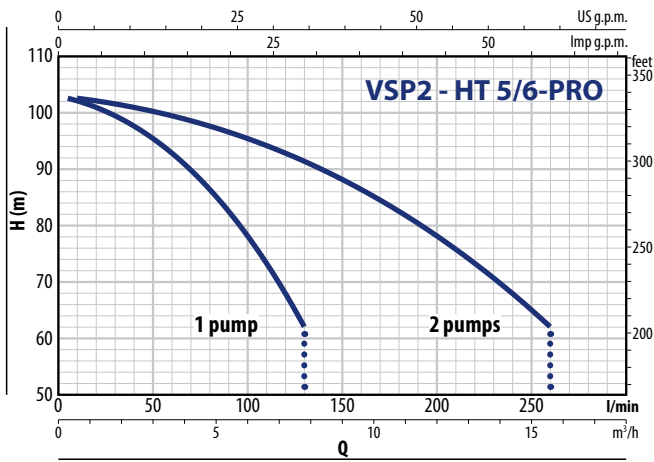

ABSORPTION

TYPE	VOLTAGE
Single-phase	230 V
VSP2m - HT 3/4 PRO	2 x 7.5 A
VSP2m - HT 3/5 PRO	2 x 9.0 A
VSP2m - HT 3/6 PRO	2 x 10.5 A
VSP2m - HT 5/2 PRO	2 x 7.0 A
VSP2m - HT 5/3 PRO	2 x 8.0 A
VSP2m - HT 5/4 PRO	2 x 9.5 A
VSP2m - HT 8/3 PRO	2 x 8.5 A
VSP2m - HT 8/4 PRO	2 x 10.0 A

TYPE	VOLTAGE
Three-phase	400 V
VSP2 - HT 3/4 PRO	2 x 2.5 A
VSP2 - HT 3/5 PRO	2 x 3.0 A
VSP2 - HT 3/6 PRO	2 x 3.5 A
VSP2 - HT 3/7 PRO	2 x 4.2 A
VSP2 - HT 5/2 PRO	2 x 2.3 A
VSP2 - HT 5/3 PRO	2 x 2.4 A
VSP2 - HT 5/4 PRO	2 x 3.2 A
VSP2 - HT 5/5 PRO	2 x 4.0 A
VSP2 - HT 5/6 PRO	2 x 4.3 A
VSP2 - HT 8/3 PRO	2 x 3.0 A
VSP2 - HT 8/4 PRO	2 x 3.4 A
VSP2 - HT 8/5 PRO	2 x 4.0 A
VSP2 - HT 8/6 PRO	2 x 4.5 A

DIMENSIONS AND WEIGHT

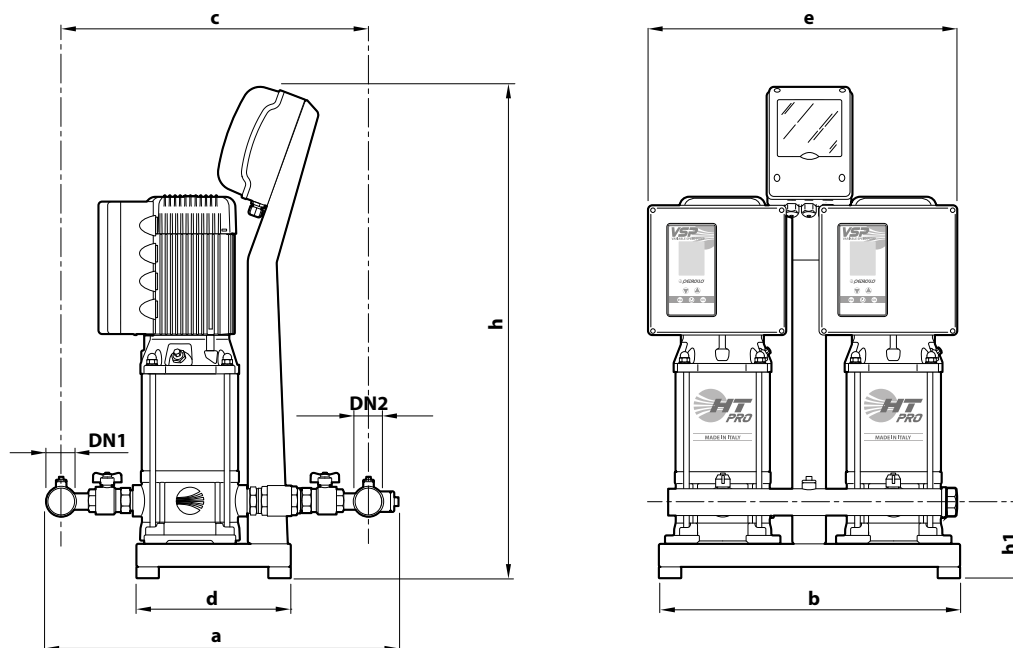

TYPE		PORTS		DIMENSIONS mm							kg		
Single-phase	Three-phase	DN1	DN2	a	b	c	d	e	h	h1	1~	3~	
VSP2m-HT 3/4 PRO	VSP2-HT 3/4 PRO	2"	2"	694	530	576	270	542	863	135	97	97	
VSP2m-HT 3/5 PRO	VSP2-HT 3/5 PRO										97	97	
VSP2m-HT 3/6 PRO	VSP2-HT 3/6 PRO										100	100	
-	VSP2-HT 3/7 PRO										-	110	
VSP2m-HT 5/2 PRO	VSP2-HT 5/2 PRO	2"	2"	740	530	622	270	542	863		135	96	96
VSP2m-HT 5/3 PRO	VSP2-HT 5/3 PRO											96	96
VSP2m-HT 5/4 PRO	VSP2-HT 5/4 PRO											100	100
-	VSP2-HT 5/5 PRO									-		105	
-	VSP2-HT 5/6 PRO	-	107										
VSP2m-HT 8/3 PRO	VSP2-HT 8/3 PRO	2½"	2½"	833	530	698	270	542	863	140		101	101
VSP2m-HT 8/4 PRO	VSP2-HT 8/4 PRO											105	105
-	VSP2-HT 8/5 PRO										-	112	
-	VSP2-HT 8/6 PRO										-	114	