

-  Clean water
-  Domestic use
-  Civil use



TS1-4CP 100



TS1-5CR 100



TS1-2CP

INSTALLATION AND USE

The **TISSEL-100** is a pumping unit designed for water supply and pressure boosting in residential settings, as well as for irrigation purposes. It seamlessly integrates with various pressurization systems, including existing ones, ensuring optimal comfort and significant energy savings.

PRODUCT DESCRIPTION

TISSEL-100 is a system comprising a pump and a water flow inverter with an integrated pressure sensor. It adjusts the motor speed based on water demand, maintaining constant system pressure.

TISSEL-100 is a plug-and-play product requiring no configuration. Users can adjust the system's working pressure and view operating parameters or alarms via the user interface. Experienced users can access advanced menus to customize factory settings for specific plant conditions. **TISSEL-100** includes a pump and a water flow inverter with an integrated pressure sensor, ensuring consistent pressure by adjusting motor speed based on water demand.

TISSEL-100 is a plug-and-play product that eliminates the need for configuration procedures. Users can easily adjust the system's operating pressure and monitor essential parameters or alarm messages via the user interface. For advanced users, **TISSEL-100** provides access to advanced menus for modifying factory parameters, allowing customization to meet specific facility conditions or system requirements.

TISSEL-100 is designed to protect the system from:

- ✘ dry running
- ✘ overcurrent
- ✘ overvoltage and undervoltage
- ✘ combustion chamber
- ✘ short circuit

TECHNICAL DATA

- Power supply: **1~ 230 V ± 10%**
- Output voltage: **3~ 230 V**
- Frequency: **50/60 Hz**
- Maximum liquid temperature: **+40 °C**
- Maximum ambient temperature: **+40 °C**

COMPONENTS INCLUDED

- ✘ Three-phase pump
- ✘ Variable frequency drive with integrated non-return valve
- ✘ GSR quick-connect coupling
- ✘ 1.5 metres cable with Schuko plug

KEY FEATURES

- ✘ **Plug&Play** solution, ease of installation, and quick start-up
- ✘ Enhanced comfort ensured by consistent pressure operation
- ✘ Save energy with lower pump consumption.
- ✘ Protects the pump from faults by monitoring hydraulic and electrical operating parameters
- ✘ Reduced noise operation

PERFORMANCE RANGE

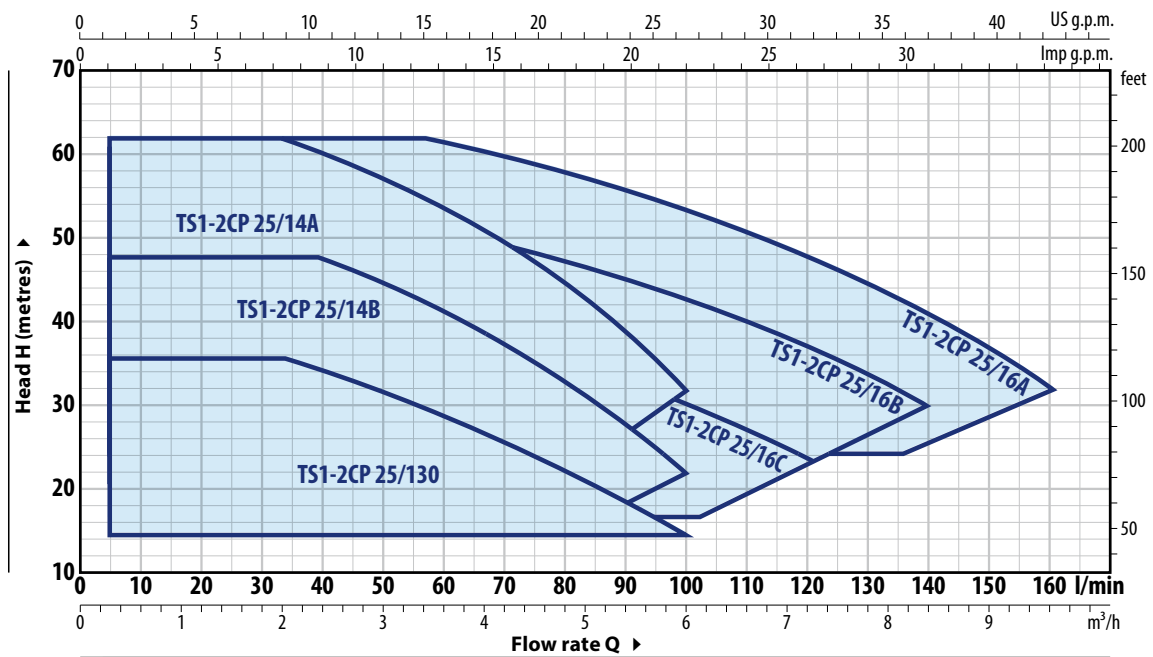
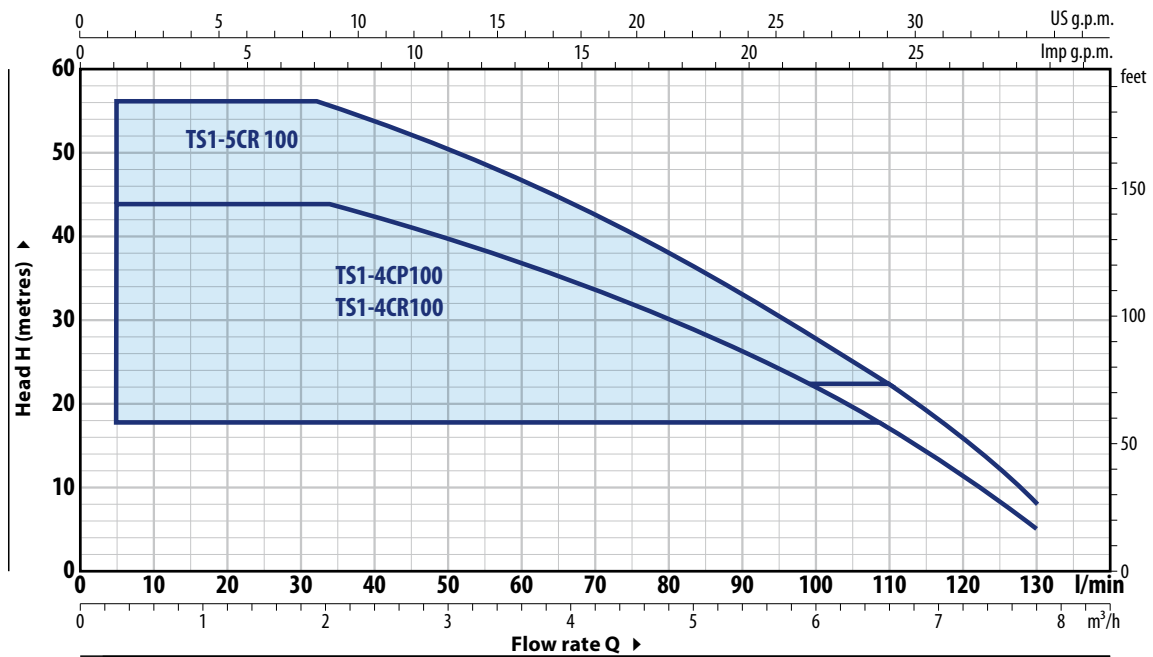

TYPE	POWER P ₂		ABSORPTION 230 V	PERFORMANCE		PERFORMANCE (ADJUSTABLE SET POINT)						
	kW	HP ▲		Q litres/min	H metres	Set Point Min		Set Point Calibration Std		Set Point Max		
Single-phase						bar	litres/min	bar	litres/min	bar	litres/min	
TS1-4CP 100	0.75	1	IE3	9.2 A	5 – 130	44 – 5	1.8	5 – 107	3.0	5 – 80	4.3	5 – 33
TS1-4CR 100	0.75	1		9.2 A	5 – 130	44 – 5	1.8	5 – 107	3.0	5 – 80	4.3	5 – 33
TS1-5CR 100	0.90	1.25		10.0 A	5 – 130	56 – 8	2.2	5 – 107	3.7	5 – 80	5.5	5 – 33
TS1-2CP 25/130	0.75	1	IE3	9.5 A	5 – 100	36 – 15	1.5	5 – 100	2.5	5 – 67	3.5	5 – 34
TS1-2CP 25/14B	1.1	1.5		10.5 A	5 – 100	48 – 22	1.9	5 – 92	3.6	5 – 70	4.7	5 – 35
TS1-2CP 25/14A	1.5	2		16.0 A	5 – 100	61 – 32	2.4	5 – 85	4.8	5 – 70	6.0	5 – 35
TS1-2CP 25/16C	1.1	1.5		11.5 A	5 – 120	41 – 24	1.7	5 – 100	3.2	5 – 85	4.0	5 – 52
TS1-2CP 25/16B	1.5	2		13.5 A	5 – 140	52 – 30	2.0	5 – 110	4.1	5 – 100	5.1	5 – 52
TS1-2CP 25/16A	2.2	3		21.5 A	5 – 160	62 – 32	2.4	5 – 135	4.8	5 (115)	6.1	5 – 52

Q = Flow rate H = Total manometric head

▲ Three-phase motor efficiency class (IEC 60034-30-1)

TISSEL-100

PERFORMANCE CURVES

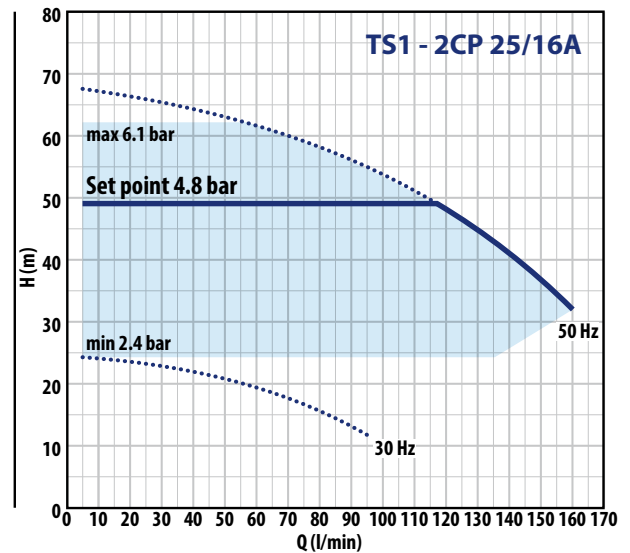
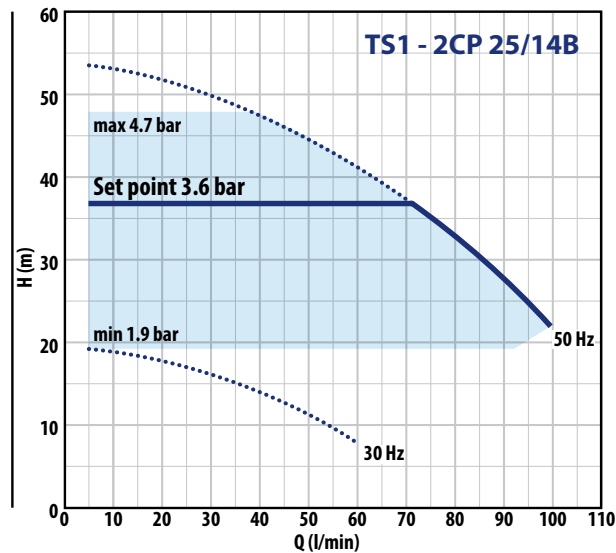
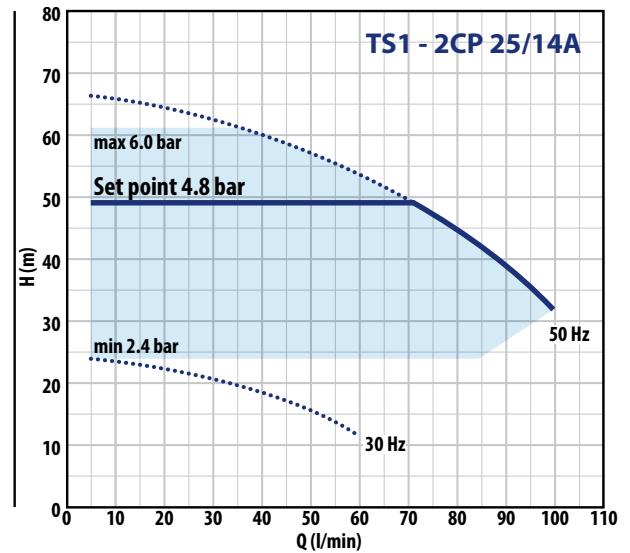
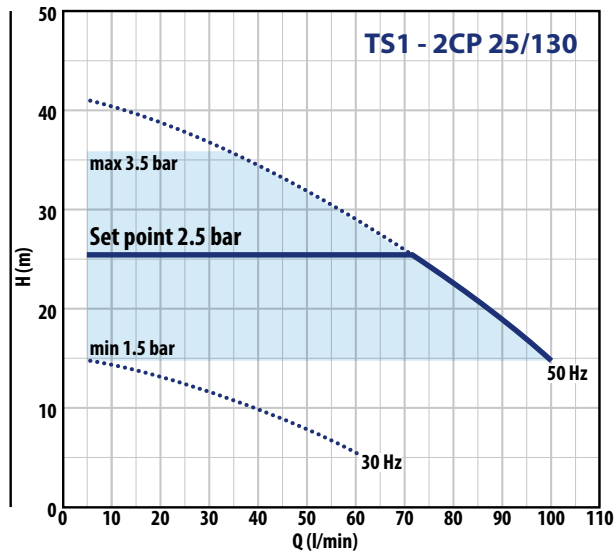
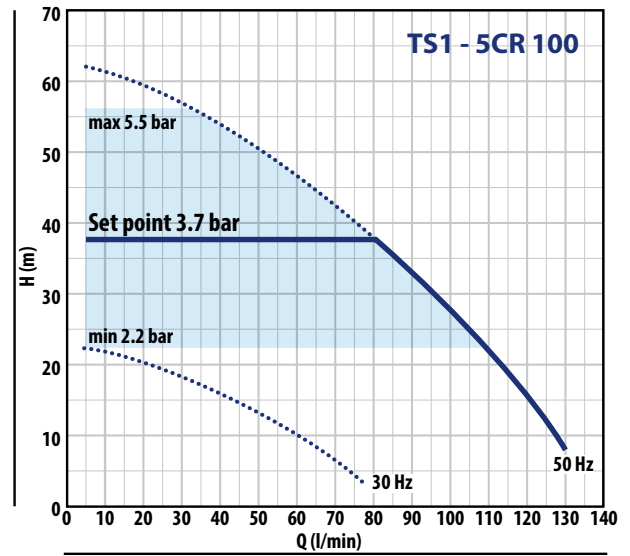
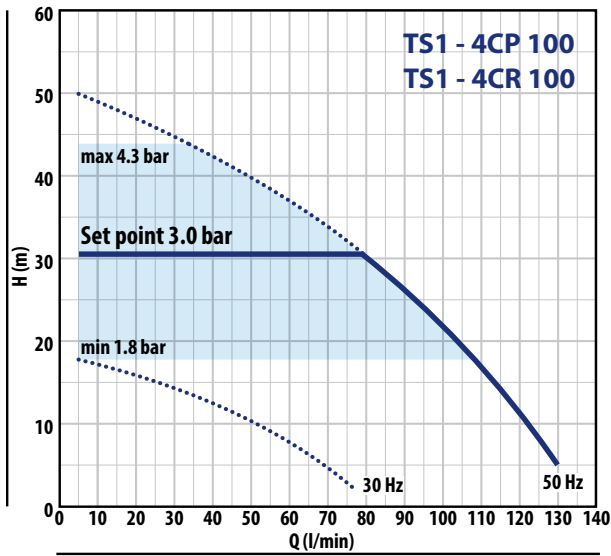

PERFORMANCE CURVES

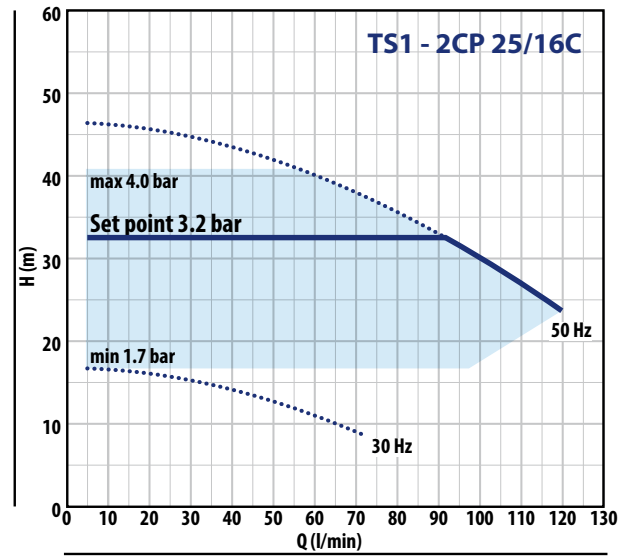
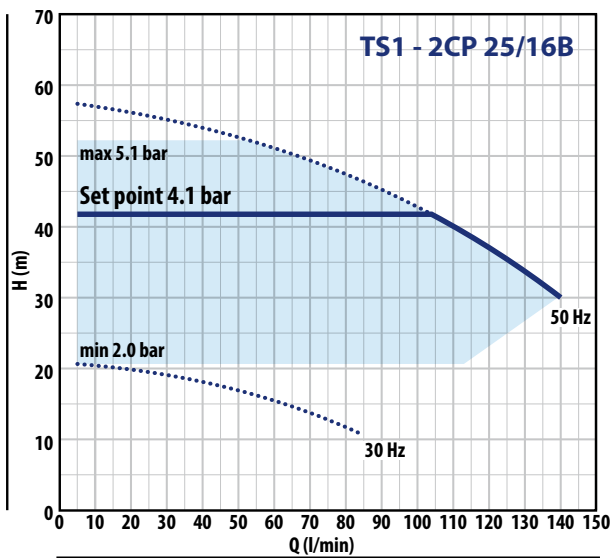

DIMENSIONS (mm)

TS1-4CP 100

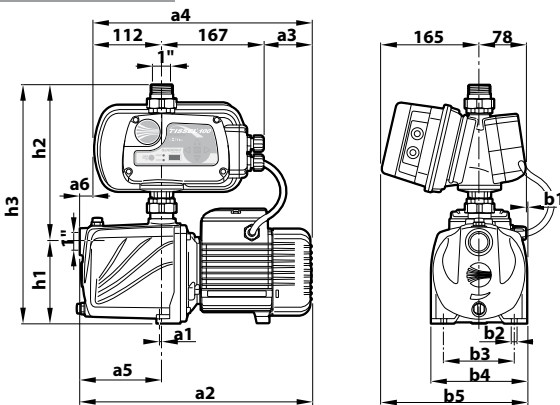

TS1-4CR 100X - TS1-5CR 100

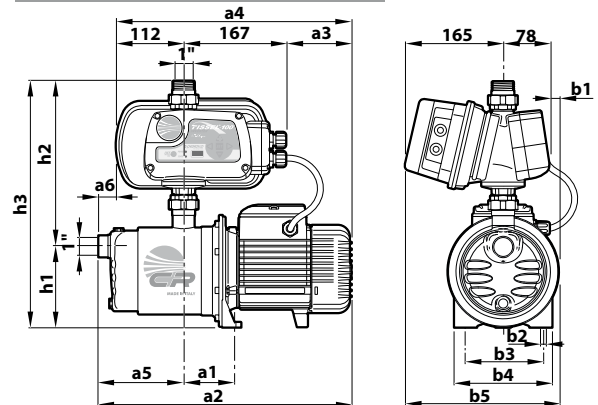

TS1-2CP 25/130

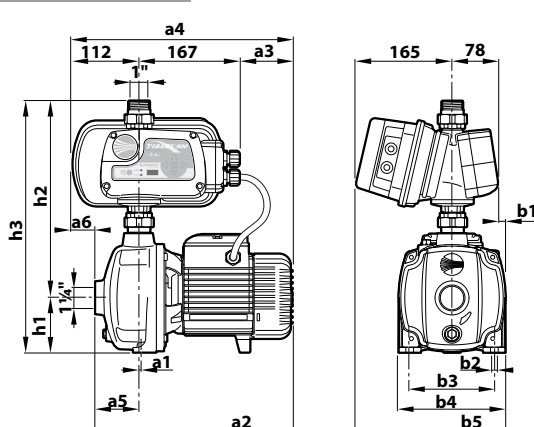

TS1-2CP 25/14 - TS1-2CP 25/16

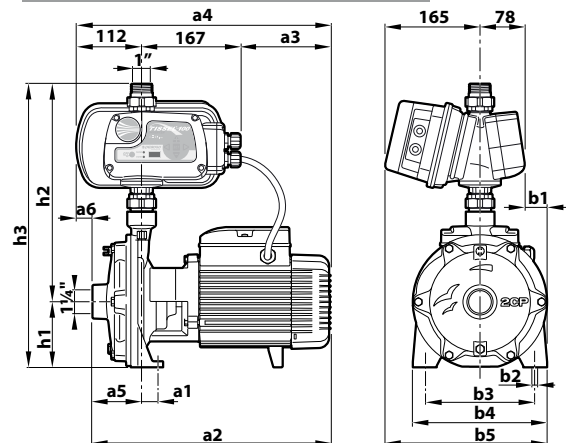

TYPE	a1	a2	a3	a4	b1	b2	b3	b4	b5	h1	h2	h3	kg
TS1-4CP 100	1.5	382	79	358	1	9	116	158	244	134	268	402	21.7
TS1-4CR 100	87	411	106	385	13	10	120	182	256	132	280	412	18.5
TS1-5CR 100	87	411	106	385	13	10	120	182	256	132	280	412	18.5
TS1-2CP 25/130	1	330	90	369	12	10	142	180	255	92	339	431	22.7
TS1-2CP 25/14B	17	404	155	434	22	10	162	200	265	93	360	453	28.6
TS1-2CP 25/14A	26	404	155	434	34	11	185	225	278	110	381	491	32.6
TS1-2CP 25/16C	17	404	155	434	22	10	162	200	265	93	360	453	28.4
TS1-2CP 25/16B	26	404	155	434	34	11	185	225	278	110	381	491	32.4
TS1-2CP 25/16A	26	424	175	454	34	11	185	225	278	110	381	491	35.2