



### ※ Particularly quiet, energy-efficient multi-stage pumps equipped with stainless steel impeller

#### PERFORMANCE RANGE

- Flow rate up to **130 l/min** (7.8 m<sup>3</sup>/h)
- Head up to **67 m**

#### INSTALLATION AND USE

They are recommended for pumping clean water and chemically non-aggressive liquids for the pump materials.

Due to their reliability and quietness, they are widely used in the domestic sector and especially for water distribution coupled with small or medium-sized autoclave tanks, for irrigating vegetable gardens or orchards, etc.

#### ELECTRIC MOTOR

Three-phase pumps are equipped with high-efficiency motors (IEC 60034-30-1).

Efficiency class **IE3** for three-phase motors and **IE2** for single-phase motors, with class F insulation and IPX4 protection.

#### APPLICATION LIMITS

- Manometric suction head up to **7 m**
- Liquid temperature between **-10 °C** and **+60 °C**
- Ambient temperature up to **+40 °C**
- Maximum working pressure **6 bar**

#### PATENTS - TRADE MARKS - MODELS

- Registered Community Model No. 002073635-0001

#### AVAILABLE UPON REQUEST

- ※ Technopolymer impeller (cost-effective version)
- ※ Different voltage requirements 60 Hz frequency

**CURVES AND PERFORMANCE DATA – HS=0 m**

**50 Hz**

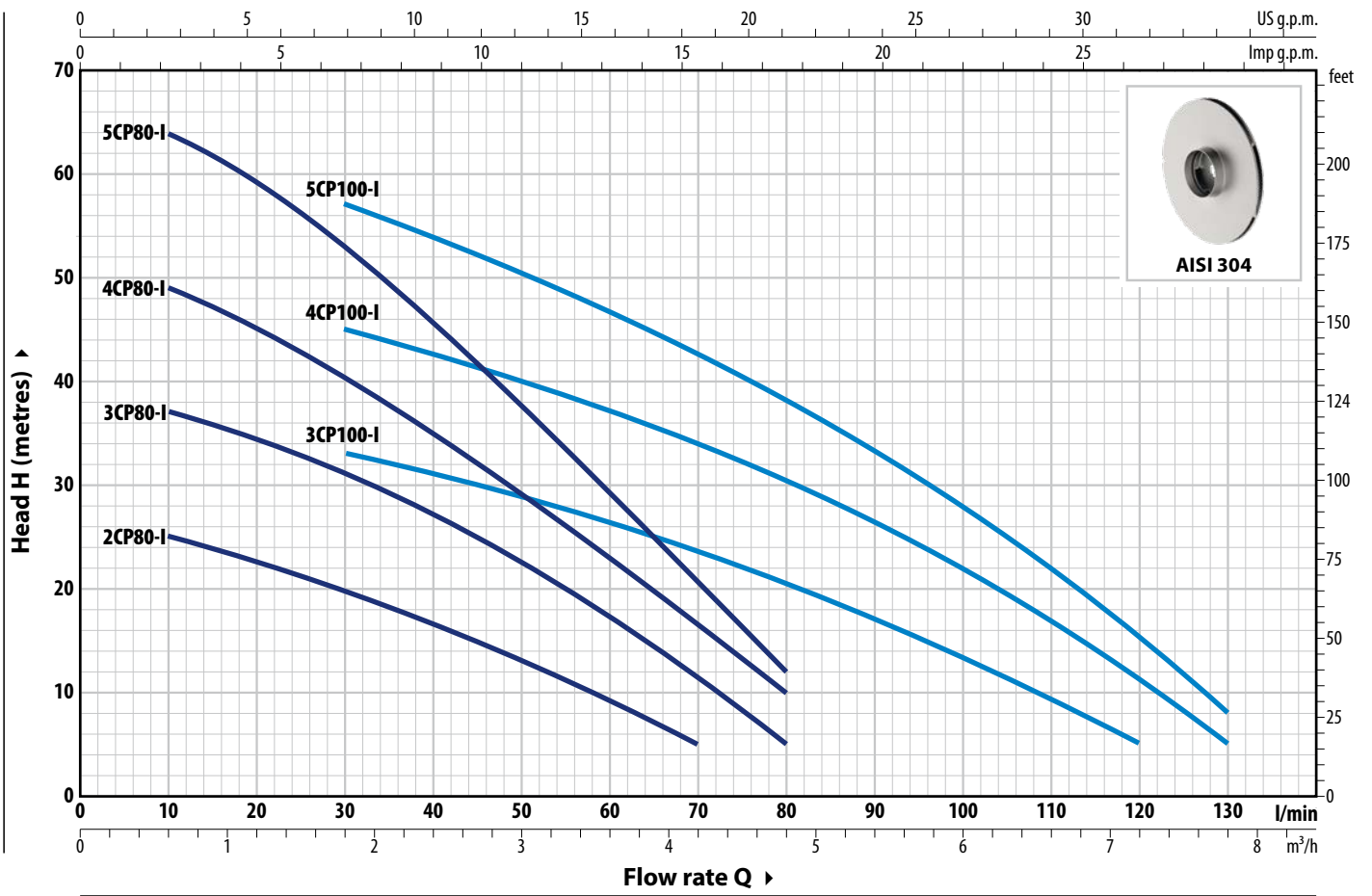

TYPE		POWER (P <sub>2</sub> )		1~3~	Q	H metres																
Single-ph.	Three-ph.	kW	HP			0	0.3	0.6	1.2	1.8	2.4	3.0	3.6	4.2	4.8	5.4	6.0	6.6	7.2	7.8		
						0	5	10	20	30	40	50	60	70	80	90	100	110	120	130		
2CPm 80-I	2CP 80-I	0.30	0.40	IE2 IE3	H metres	27	26	25	22.5	20	16.5	13	9	5								
3CPm 80-I	3CP 80-I	0.45	0.60			40	38	37	34.5	31	27	22.5	17	11	5							
4CPm 80-I	4CP 80-I	0.55	0.75			52	50	49	44.5	40	34	28.5	22.5	16	10							
5CPm 80-I	5CP 80-I	0.75	1			67	66	64	59	53	45.5	37.5	29.5	20.5	12							
3CPm 100-I	3CP 100-I	0.55	0.75			38	37	36	34.5	33	31	28	26	23	20	17	13.5	10	5			
4CPm 100-I	4CP 100-I	0.75	1	50	50	49	47	45	42	39.5	37	34	30.5	26.5	22	17	11	5				
5CPm 100-I	5CP 100-I	0.90	1.25	63	62	61.5	59.5	57	53.5	50.5	46.5	42.5	38	33	28	22	15	8				

Q = Flow rate H = Total manometric head HS = Suction height

Performance curves comply with EN ISO 9906 Grade 3B tolerance limits.

# 2-5CP - I Technical data

## ABSORPTION

TYPE	VOLTAGE
<b>Single-phase</b>	<b>230 V</b>
<b>2CPm 80-I</b>	2.3 A
<b>3CPm 80-I</b>	3.2 A
<b>4CPm 80-I</b>	3.9 A
<b>5CPm 80-I</b>	5.3 A
<b>3CPm 100-I</b>	4.1 A
<b>4CPm 100-I</b>	5.8 A
<b>5CPm 100-I</b>	6.8 A

TYPE	VOLTAGE	
	<b>230 V - Δ</b>	<b>400 V - 人</b>
<b>2CP 80-I</b>	1.7 A	1.0 A
<b>3CP 80-I</b>	2.6 A	1.5 A
<b>4CP 80-I</b>	3.5 A	2.0 A
<b>5CP 80-I</b>	4.3 A	2.5 A
<b>3CP 100-I</b>	3.5 A	2.0 A
<b>4CP 100-I</b>	4.3 A	2.5 A
<b>5CP 100-I</b>	4.3 A	2.5 A

## DIMENSIONS AND WEIGHT

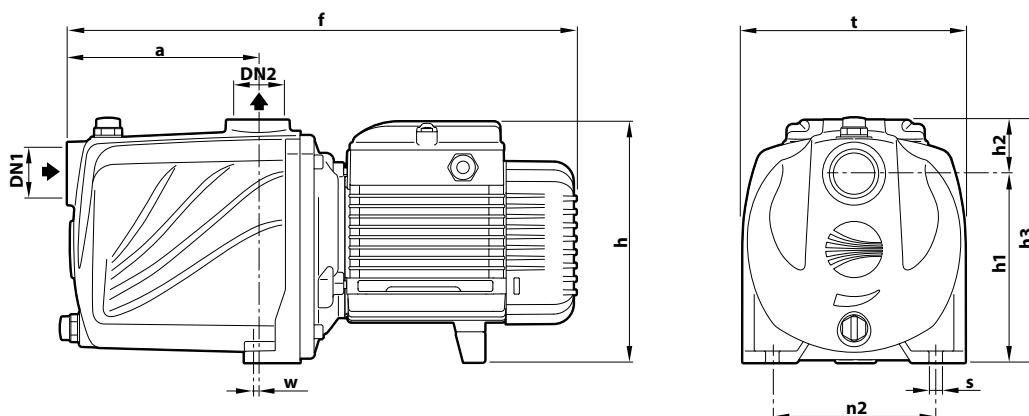

TYPE		PORTS		DIMENSIONS mm										kg	
Single-phase	Three-phase	DN1	DN2	a	f	h	h1	h2	h3	t	n2	w	s	1~	3~
<b>2CPm 80-I</b>	<b>2CP 80-I</b>	1"	1"	110	338	172	134	38	172	158	118	1	10	9.7	9.7
<b>3CPm 80-I</b>	<b>3CP 80-I</b>													10.7	10.7
<b>4CPm 80-I</b>	<b>4CP 80-I</b>			12.2	11.5										
<b>5CPm 80-I</b>	<b>5CP 80-I</b>			15.1	15.1										
<b>3CPm 100-I</b>	<b>3CP 100-I</b>			11.4	10.7										
<b>4CPm 100-I</b>	<b>4CP 100-I</b>			14.9	15.5										
<b>5CPm 100-I</b>	<b>5CP 100-I</b>			14.9	15.7										

(\*) h=221 mm for single-phase 110 V versions

## PALLET CAPACITY

TYPE		NO. OF PUMPS
Single-phase	Three-phase	
<b>2CPm 80-I</b>	<b>2CP 80-I</b>	84
<b>3CPm 80-I</b>	<b>3CP 80-I</b>	84
<b>4CPm 80-I</b>	<b>4CP 80-I</b>	84
<b>5CPm 80-I</b>	<b>5CP 80-I</b>	72
<b>3CPm 100-I</b>	<b>3CP 100-I</b>	84
<b>4CPm 100-I</b>	<b>4CP 100-I</b>	72
<b>5CPm 100-I</b>	<b>5CP 100-I</b>	72

## MATERIALS AND COMPONENTS

**1 Pump body** Cast iron with cataphoresis treatment with ISO 228/1 threaded ports

**2 Cover** Stainless steel **AISI 304**

**3 Impellers** Stainless steel **AISI 304**

**4 Diffusers** Noryl™ complete with wear rings

5 Mechanical seal	Seal	Shaft	Materials
	<b>AR-13</b>	Ø 13 mm	Ceramic / Graphite / NBR

**6 Motor shaft** Stainless steel **AISI 431**

**7 Electric motor** **2-5CPm -I**: single-phase 230 V - 50 Hz with winding integrated thermal motor protection  
**2-5CP -I**: three-phase 230/400 V - 50 Hz  
 ※ Pumps are equipped with high-efficiency motors (IEC 60034-30-1)  
 class **IE2** for single-phase models  
 class **IE3** for three-phase models  
 Continuous running duty **S1**

